

DETTAGLIO A  
SCALA 1 : 4

# INDIVIDUAL PACKING RAL 3005

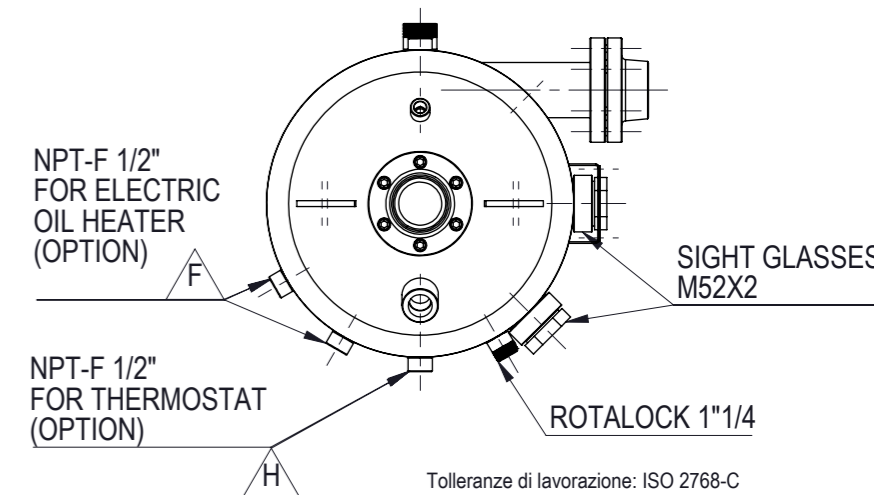
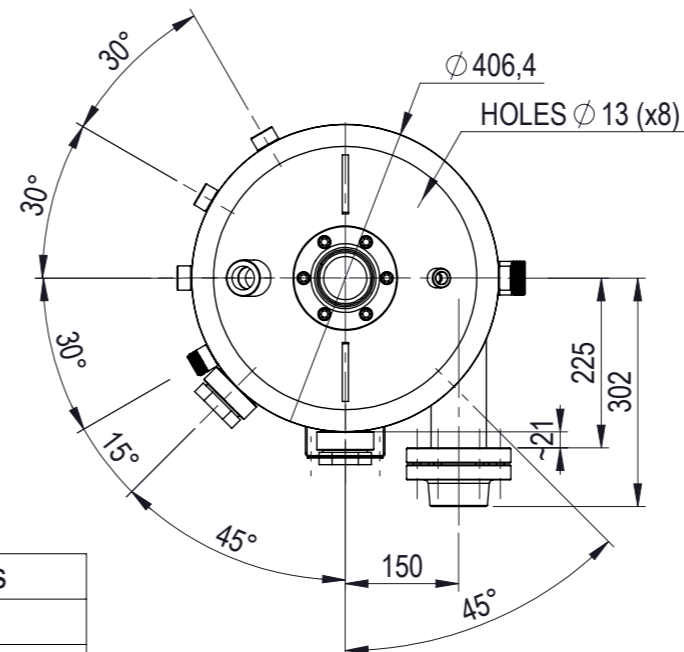
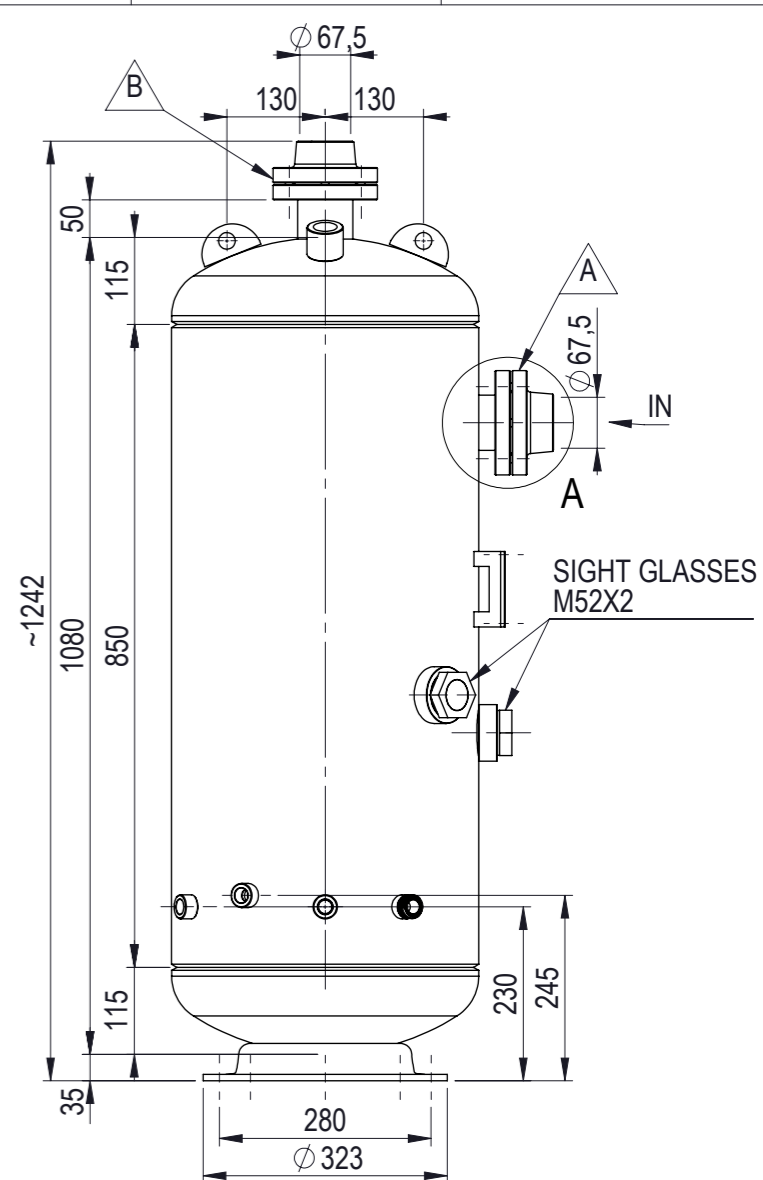
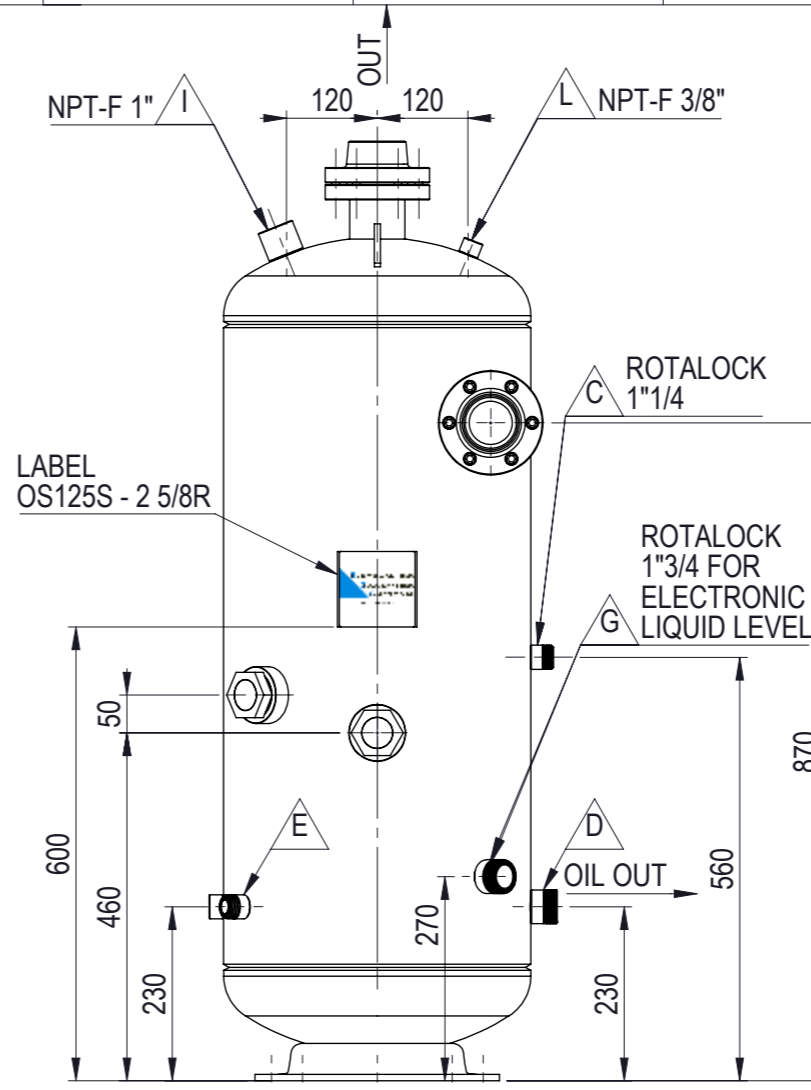

Item Number	Description	Quantity
1	HEAD Ø406	2
2	TUBE Ø406,4	1
3	TUBE ODØ73	1
4	TUBE ODØ73	1
5	EYELIFT	2
6	PLATE SUPPORT 105X100	1
7	BASE SUPPORT Ø323 H.Ø13	1
8	ROTALOCK 1"3/4 - 12UN	2
9	SIGHT GLASS SLEEVE M52X2	2
10	1" NPT-F	1
11	1/2" NPT-F	3
12	3/8" NPT-F	1
13	ROTALOCK 1"1/4 - 12 UNF	2
14	MALE FLANGE Ø138 ODSØ67,5	2
15	FEMALE FLANGE Ø138X20 FIL.M10	2
16	SCREW M10X30	12
17	SIGHT GLASS M52X2 DS40 (TÜV)	2
18	GASKET FLANGE	2
19	SIGHT GLASS GASKET M52X2	2
20	METAL LABEL	1

Pos	Connections
A	IN
B	OUT
C	PRE-CHARGE OIL IN
D	OIL OUT (MAIN)
E	OIL OUT (SEC.)
F	OIL HEATER
G	LIQUID LEVEL
H	THERMOSTAT
I	SAFETY VALVE
L	ACCESSORY

Rev.	Data-Date	Dis.-Draftsman	Visto-Checked by	Descrizione Revisione - Revision Description
Denominazione - Denomination				Codice Disegno - Drawing Code
<b>OIL.SEP.125LT.Ø406X1080 PS32BAR - OS125S-2 5/8R</b>				<b>SOIR125A</b>
PS - Design	PW - Work	PT - Test	Temperatura - Temperature	Refrigerant
32 BAR	32 BAR	48 BAR	-10°C +120°C	HFC, HCFC
Scala-Scale		Data-Date	Disegnatore - Draftsman	Visto-Checked by
1:10		21/05/2014	G.BOKARIS	S.SPINELLO
Materiale - Material		Spessore - Thickness	Colore Vernice-Painted Colour	Prodotto e Realizzato Secondo Direttiva 97/23/CE
			RAL 3005 - RED	Produced and Made According to Directive 97/23/CE
Categoria PED				Cod.STD.
CAT.IV				OS90A
Peso - Weight [kg]				
106.22				

