



2VGR25 250A

B22-D8 p



DATA SHEET

release. c - Revision 01-2014

Replace Z21-14 p

Voltage	Frequency	Absorbed Power	Absorbed Current	Capacitor	Airflow	Rotation speed	Acoustic level	Rotation	Operational Temperature
V	Hz	W	A	μF	m³/h	RPM	dBA		Min/Max
230	50	104	0,47	4,0	1665	2725	65	R	-20°C / +70°C
230	60	135	0,59	4,0	1835	3105	68	R	-20°C / +70°C
230	50				980 CFM				-4°F / 158°F
230	60				1080 CFM				-4°F / 158°F



dBA : free blowing

NA : not applicable

ErP 2013

NA

ErP 2015

NA

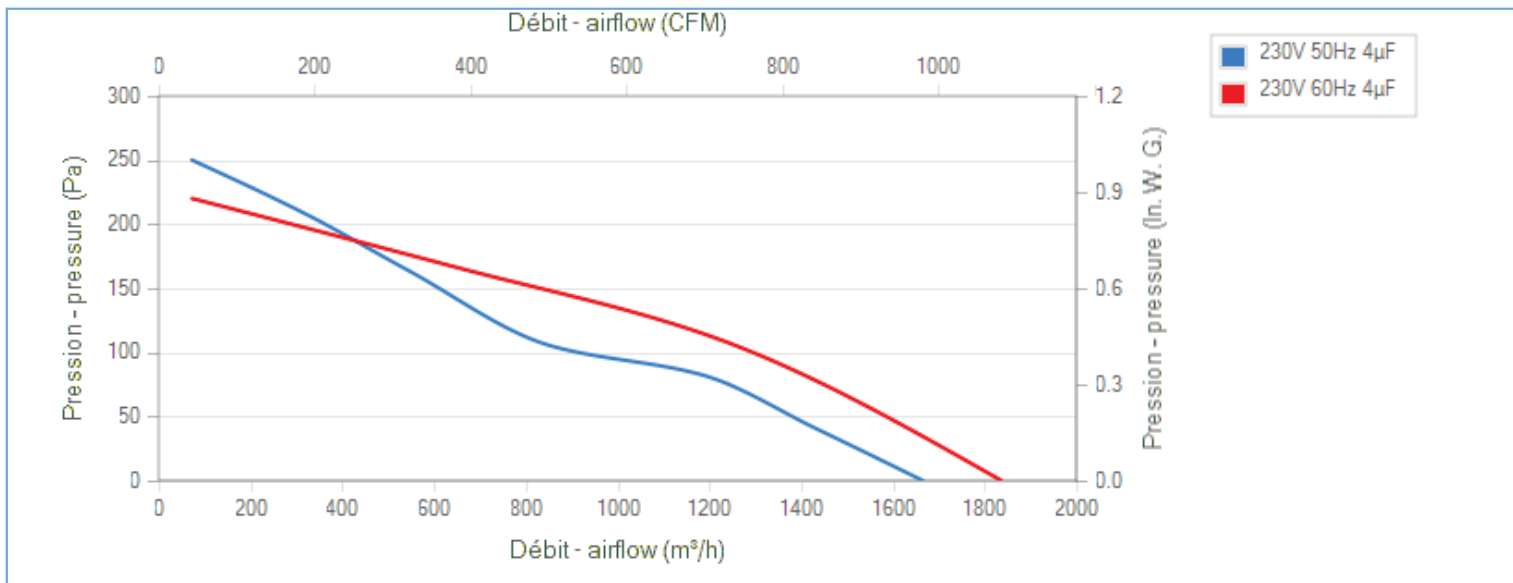
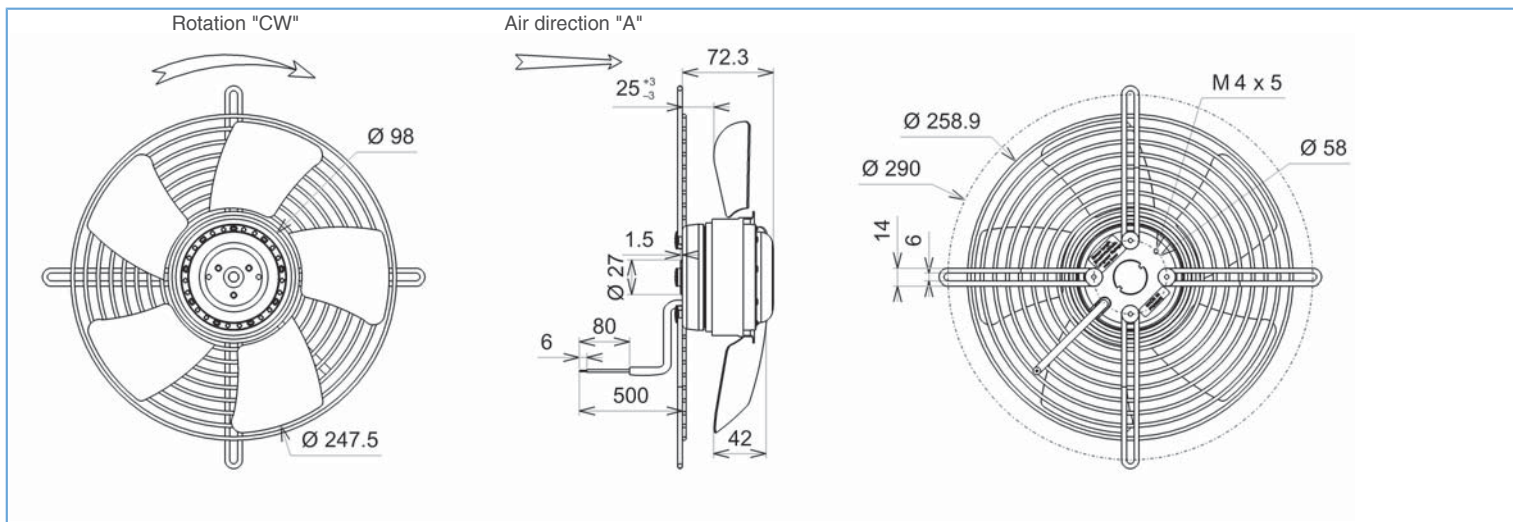

Tested with ECOFIT ring

Description

- .Weight : 2,2 Kg
- .Ball bearing
- .Class F, thermally protected
- .IP44 protection depending on installation and position as per EN60034-5
- .G6.3 balancing
- .Zinc coated impeller
- .Rotor and impeller : black paint
- .Finger guard : black paint

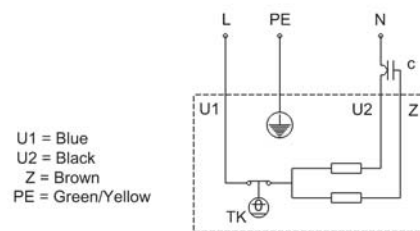



2VGR25 250A

B22-D8 p



DATA SHEET

release. c - Revision 01-2014

Replace Z21-14 p

Data in accordance to ErP directive

Voltage	230	V
Frequency	50	Hz
Power	0,117	kW ⁽¹⁾
Airflow	1182	m ³ /h ⁽¹⁾
Pressure	83	Pa ⁽¹⁾
Rotation speed	2095	RPM ⁽¹⁾

(1) at optimal efficiency point

ErP directive (EU 2009/125/EC) not applicable :
Power at optimum energy efficiency point <125W

Accessories

Capacitor for 50Hz	19019
Capacitor for 60Hz	19019
Connecting box	39658
Connector	09172

Measurement setup

16085 VIROLE V250 RONDE

Documents

- Manuel d'utilisation www.ecofit.com/site/normes
- Operating and recycling manual www.ecofit.com/anglais/normes

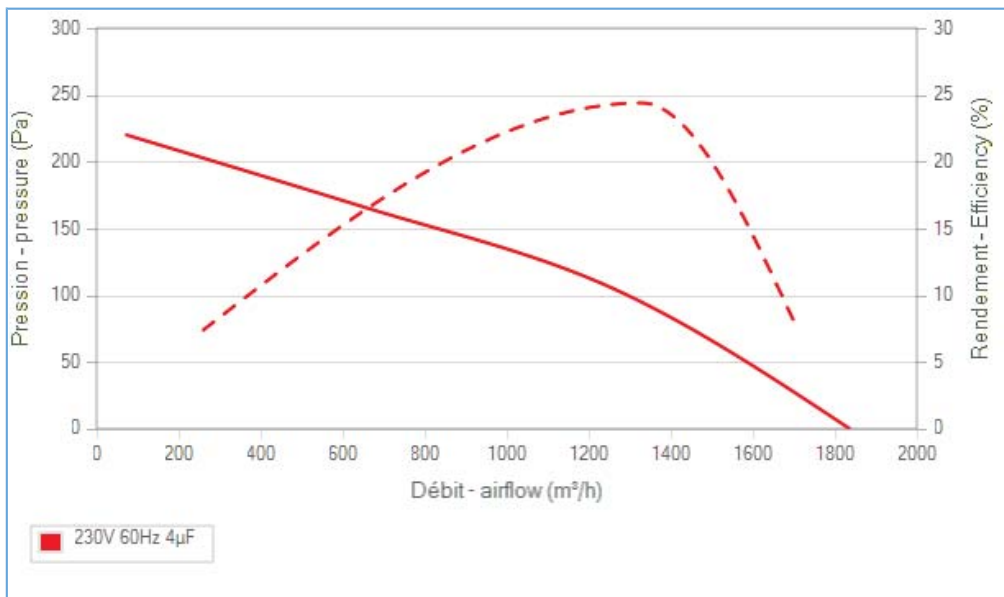
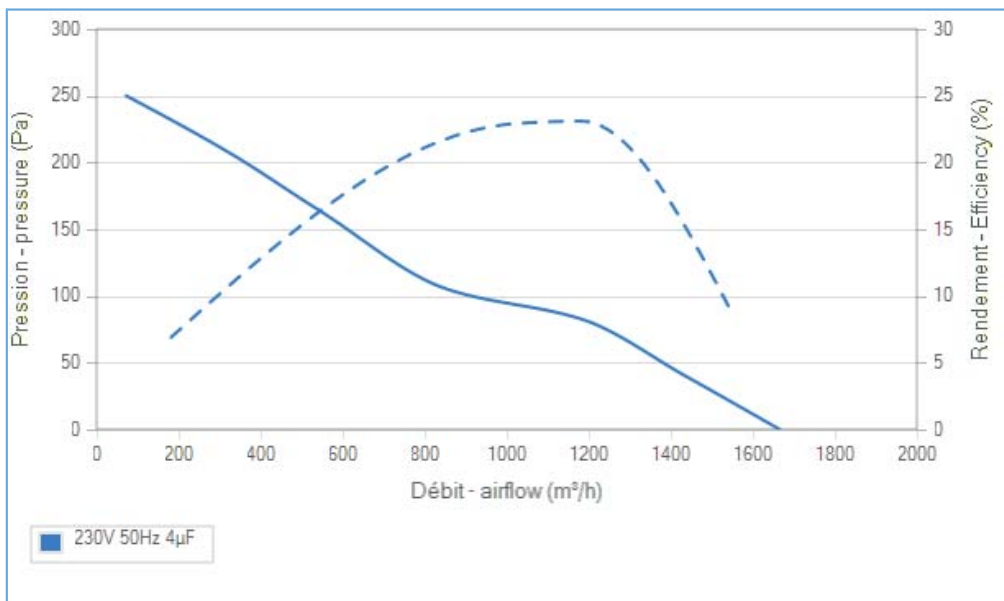

Non contractual document. All specifications are subject to change without prior notice. Picture for information only.



A041865
2RS925CN