

GEA Bock HGZ7

Assembly instructions

09726-06.2018-Gb

Translation of the original instructions

HGZX7/1620-4 R404A/R507	HGZX7/1620-4 R410A
HGZX7/1860-4 R404A/R507	HGZX7/1860-4 R410A
HGZX7/2110-4 R404A/R507	HGZX7/2110-4 R410A

HGZX7/1620-4 R448A/R449A	HGZ7/1620-4 R22
HGZX7/1860-4 R448A/R449A	HGZ7/1860-4 R22
HGZX7/2110-4 R448A/R449A	HGZ7/2110-4 R22

About these instructions

Read these instructions before assembly and before using the compressor. This will avoid misunderstandings and prevent damage. Improper assembly and use of the compressor can result in serious or fatal injury.

Observe the safety instructions contained in these instructions.

These instructions must be passed onto the end customer along with the unit in which the compressor is installed.

Manufacturer

GEA Bock GmbH
72636 Frickenhausen

Contact

GEA Bock GmbH
Benzstraße 7
72636 Frickenhausen
Germany

Telephone +49 7022 9454 0

Fax +49 7022 9454 137

info@gea.com

www.gea.com

GB

Contents

Page

1	Safety	4
1.1	Identification of safety instructions	
1.2	Qualifications required of personnel	
1.3	General safety instructions	
1.4	Intended use	
2	Product description	6
2.1	Short description standard design	
2.2	ain and functional parts	
2.3	Short description optional design	
2.4	Name plate	
2.5	Type key	
3	Areas of application	9
3.1	Refrigerants	
3.2	Oil charge	
3.3	Limits of application	
3.4	Subcooling temperature	
4	Description of functions	14
4.1	Two-stage refrigeration circuit with liquid subcooler	
5	Compressor assembly	16
5.1	Storage and transportation	
5.2	Setting up	
5.3	Installation of the liquid subcooler system (optional design)	
5.4	Installation example, liquid subcooler with accessories	
5.5	Factory-installed liquid subcooler system (optional design)	
5.6	Pipe connections	
5.7	Pipes	
5.8	Laying suction and pressure lines	
5.9	Operating the shut-off valves	
5.10	Operating mode of the lockable service connections	
6	Electrical connection	23
6.1	Information for contactor and motor contactor selection	
6.2	Circuit diagram for part-winding start	
6.3	Standard motor, design for direct or partial winding start	
6.4	Electronic trigger unit MP10	
6.5	Connecting the trigger unit MP10	
6.6	Functional test of the trigger unit MP10	
6.7	Oil sump heater (accessories)	
7	Commissioning	30
7.1	Preparations for start-up	
7.2	Pressure strength test	
7.3	Leak test	
7.4	Evacuation	
7.5	Refrigerant charge	
7.6	Start-up	
7.7	Avoid slugging	
8	Maintenance	33
8.1	Preparation	
8.2	Work to be carried out	
8.3	Spare parts recommendation	
8.4	Replacing the valve plates	
8.5	Extract from the lubricants table	
8.6	Decommissioning	
8.7	Accessories	
9	Technical data	36
10	Dimensions and connections	37
11	Declaration of installation	40
12	Service	42

GB

1| Safety

1.1 Identification of safety instructions:



DANGER

Indicates a dangerous situation which, if not avoided, will cause immediate fatal or serious injury.



WARNING

Indicates a dangerous situation which, if not avoided, may cause fatal or serious injury.



CAUTION

Indicates a dangerous situation which, if not avoided, may cause fairly severe or minor injury.



ATTENTION

Indicates a situation which, if not avoided, may cause property damage.



INFO

Important information or tips on simplifying work.

GB

1.2 Qualifications required of personnel



WARNING

Inadequately qualified personnel poses the risk of accidents, the consequence being serious or fatal injury. Work on compressors is therefore reserved for personnel which is qualified to work on pressurized refrigerant systems:

- For example, a refrigeration technician, refrigeration mechatronic engineer. As well as professions with comparable training, which enables personnel to assemble, install, maintain and repair refrigeration and air-conditioning systems. Personnel must be capable of assessing the work to be carried out and recognising any potential dangers.

1| Safety

1.3 General safety instructions



WARNING

Risk of accidents.

Refrigerating compressors are pressurised machines and as such call for heightened caution and care in handling.

The maximum permissible overpressure must not be exceeded, even for testing purposes.

Risk of burns!

- Depending on the operating conditions, surface temperatures of over 60°C on the discharge side or below 0°C on the suction side can be reached.

- Avoid contact with refrigerant necessarily.

Contact with refrigerant can cause severe burns and skin damage.

1.4 Intended use



WARNING

The compressor may not be used in potentially explosive environments!

GB

These assembly instructions describe the standard version of the compressor named in the title manufactured by GEA. GEA refrigerating compressors are intended for installation in a machine (within the EU according to the EU Directives 2006/42/EC Machinery Directive, 2014/68/EU Pressure Equipment Directive).

Commissioning is permissible only if the compressor has been installed in accordance with these assembly instructions and the entire system into which it is integrated has been inspected and approved in accordance with legal regulations.

The compressors are intended for use in refrigeration systems in compliance with the limits of application.

Only the refrigerant specified in these instructions may be used.

Any other use of the compressor is prohibited!

2| Product description

2.1 Short description standard version

- Semi-hermetic, two-stage, six cylinder reciprocating compressor with suction-gascooled drive motor.
- Stages divided into LP / HP at the ratio of 2 : 1
- Compressor with intermediate pressure shut-off mounted and insulated.

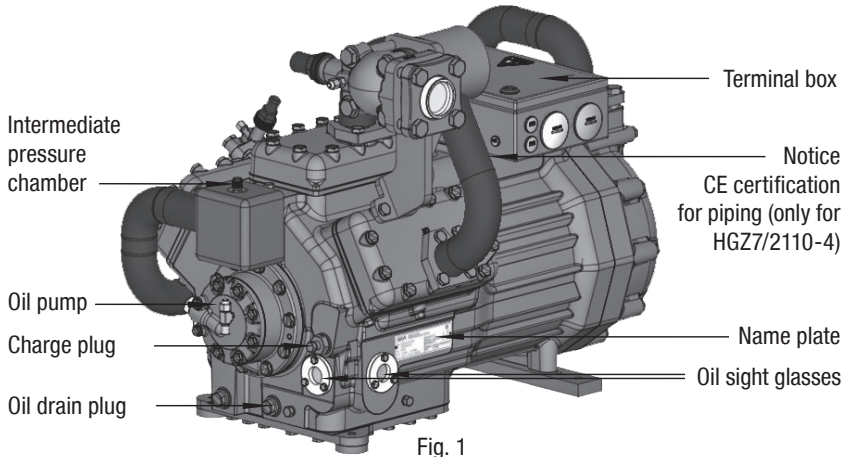

Fig. 1

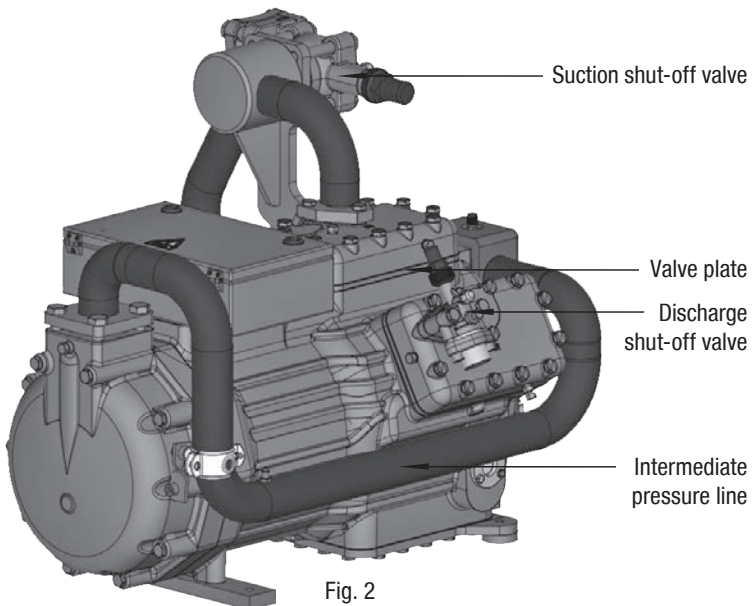

Fig. 2

Dimension and connection values can be found in Chapter 10

2| Product description

2.2 Short description optional version, enclosed

- Liquid subcooler, expansion valve, solenoid valve, filter drier and a sight glass enclosed separately, for individual, external mounting (Fig. 3).



Fig. 3

2.3 Short description optional version, mounted

- Liquid subcooler, expansion valve, solenoid valve, filter drier and a sight glass mounted directly to the compressor, piped and insulated (Fig. 4).

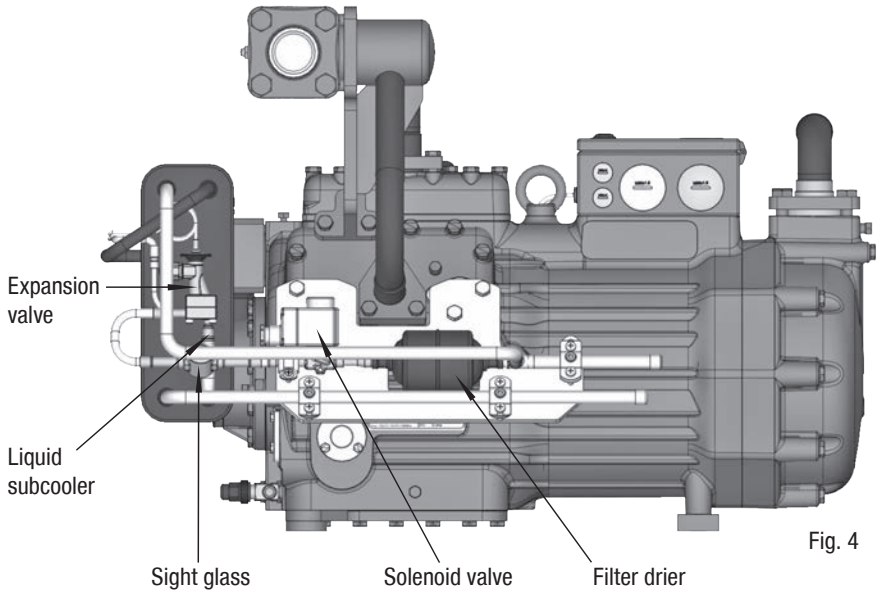

Fig. 4

Dimension and connection values can be found in Chapter 10

2| Product description

2.4 Name plate (example)



 GEA Bock GmbH 72636 Frickenhausen, Germany			
1	Typ : HGZ7/2110-4 R22	380-420V Y/YY	-3- 50HZ
2	Nr . : AN35455A040	1450 min ⁻¹ : $\dot{V}_{ND}/\dot{V}_{HD}$: 122,4/61,2 m ³ /h	8
3			9
4	I _{max} : 65,0A	440-480V Y/YY	-3- 60HZ
5	I _{block} Δ : 191A YYY : 286A	1740 min ⁻¹ : $\dot{V}_{ND}/\dot{V}_{HD}$: 146,9/73,5 m ³ /h	10
6	p _{max} : ND(LP) / HD(HP)=19/28 bar	IP54	11
		Ö1 : SP46	12
			13
			14

Fig. 5

1	Type designation	7	Voltage, circuit, frequency
2	Machine number	8	Nominal rotation speed
3	Type code	9	Displacement } 50 Hz
4	Maximum operating current		\dot{V}_{ND} = low pressure stage
5	Starting current (rotor blocked)		\dot{V}_{HD} = high pressure stage
	Y: Part winding 1	10	Voltage, circuit, frequency
	YY: Part windings 1 and 2	11	Nominal rotation speed
6	ND (LP): max. admissible operating pressure (g) Low pressure side	12	Displacement } 60 Hz
	HD (HP): max. admissible operating pressure (g) High pressure side		\dot{V}_{ND} = low pressure stage
			\dot{V}_{HD} = high pressure stage
		13	Oil type filled at the factory
		14	Terminal box protection type

 **Observe the limits of application diagrams!**

 **Electrical accessories can change the IP protection class!**

2.5 Type key (example)

HGZ X7 / 2110-4 R404A

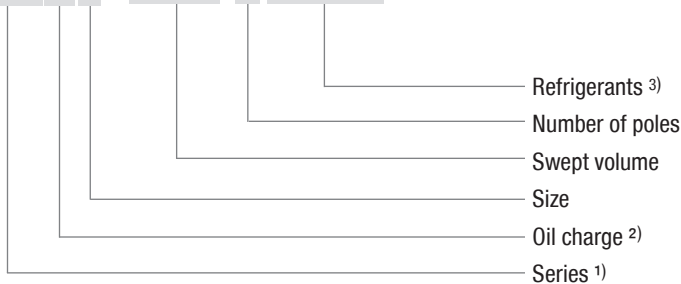

- 1) HGZ = Hermetic gas cooled (suction gas cooled), two-stage
- 2) X = Ester oil filling (HFC refrigerant R404A/R507, R410A)
- 3) Possible alternative refrigerants R404A/R507, R410A, R448A/R449A, R22

GB

3| Areas of application

3.1 Refrigerants

- HFKW : R404A/R507, R410A, R448A/R449A
- (H)FCKW: R22

3.2 Oil charge

- The compressors are filled at the factory with the following oil type:
 - für R404A/R507, R410A, R448A/R449A FUCHS Reniso Triton SE 55
 - für R22 FUCHS Reniso SP 46

Compressors with ester oil charge (FUCHS Reniso Triton SE 55) are marked with an **X** in the type designation (e.g. HGZX7/2110-4 R404A).



INFO

**For refilling, we recommend the above oil types.
Alternatives: see lubricants table, Chapter 8.5.**



ATTENTION

The oil level must be in the visible part of the sight glass; damage to the compressor is possible if overfilled or under-filled!

max.

oil level

min.

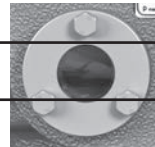

≈ 2,3 Ltr.

Fig. 6

GB

3.3 Limits of application



ATTENTION

Compressor operation is possible within the operating limits shown in the diagrams. Please note the significance of the shaded areas. Thresholds should not be selected as design or continuous operation points.

- Permissible ambient temperature (-20°C) - (+60°C)
- Max. permissible discharge end temperature 140 °C
- Max. permissible switching frequency 12x /h.
- A minimum running time of 3 min. steady-state condition (continuous operation) must be achieved.

For operation with supplementary cooling:

- Use only oils with high thermal stability.
- Avoid continuous operation near the threshold.

When operating in the vacuum range, there is a danger of air entering on the suction side. This can cause chemical reactions, a pressure rise in the condenser and an elevated compressed-gas temperature. Prevent the ingress of air at all costs!



ATTENTION

Any operation with frequency converter is inadmissible.

3 | Areas of application

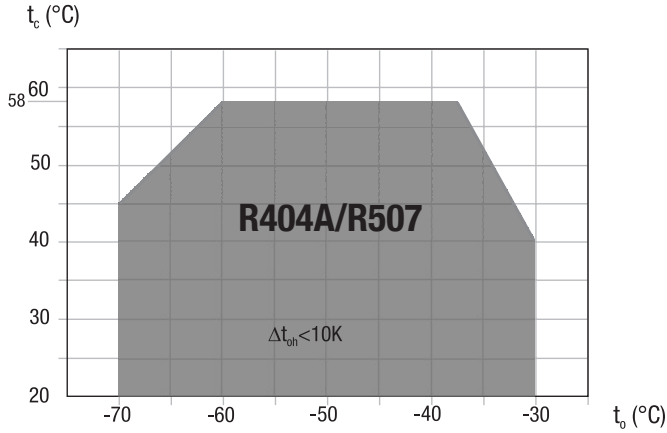

Fig. 7

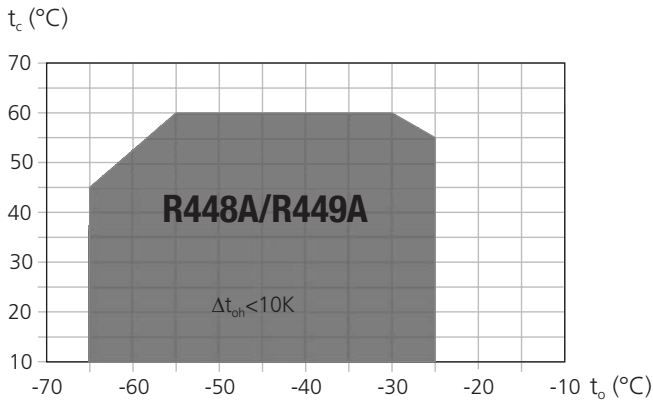

Fig. 8

 Unlimited application range

t_o Evaporation temperature (°C)

t_c Condensing temperature (°C)

Δt_{oh} suction gas superheat (K)

**Design for other areas
on request**

Max. permissible operating pressure (LP/MP/HP)¹⁾: 19/19/28 bar

¹⁾ LP = low pressure MP = intermediate pressure HP = high pressure

3 | Areas of application

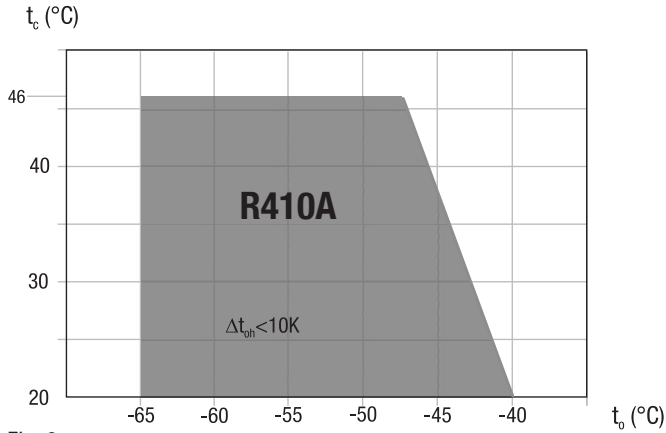

Fig. 9

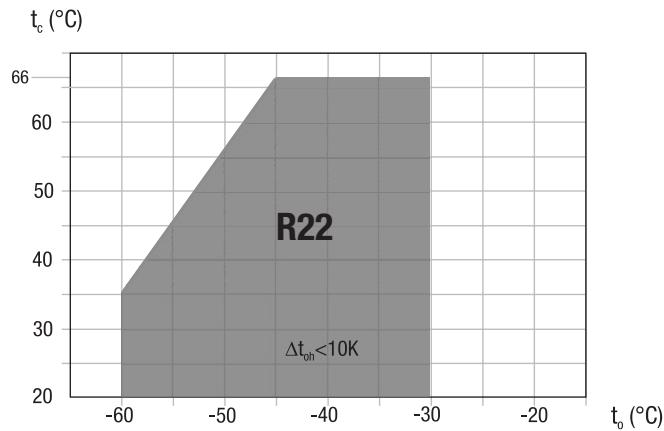

Fig. 10

 Unlimited application range

t_o Evaporation temperature (°C)

t_c Condensing temperature (°C)

Δt_{oh} suction gas superheat (K)

**Design for other areas
on request**

Max. permissible operating pressure (LP/MP/HP)¹⁾: 19/19/28 bar

¹⁾ LP = low pressure MP = intermediate pressure HP = high pressure

GB

3 | Areas of application

3.4 Subcooling temperature

The design of the expansion valve on the compressor can be defined with the help of the diagram by approximately calculating the subcooling temperature arising in the relevant operating conditions (t_0/t_c).

Diagrams for determining the subcooling temperature at the output of the liquid subcooler.

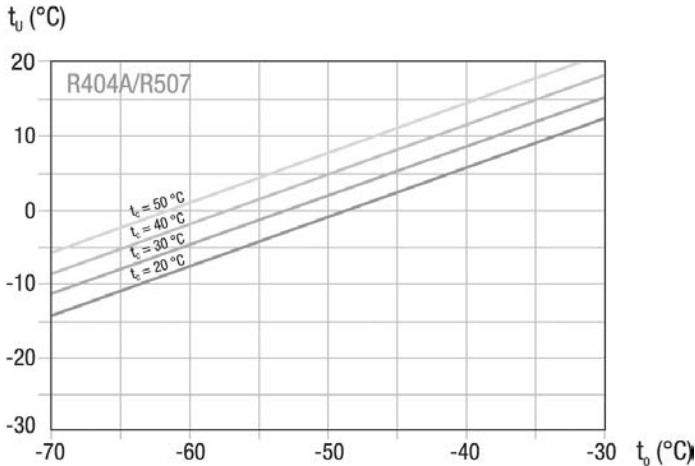

Fig. 11

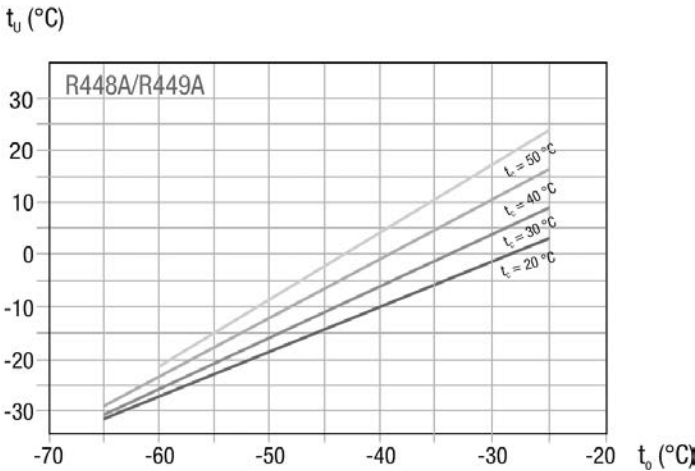

Fig. 12

t_u = Subcooling temperature at the subcooler outlet (FUA)

t_0 = Evaporating temperature

3 | Areas of application

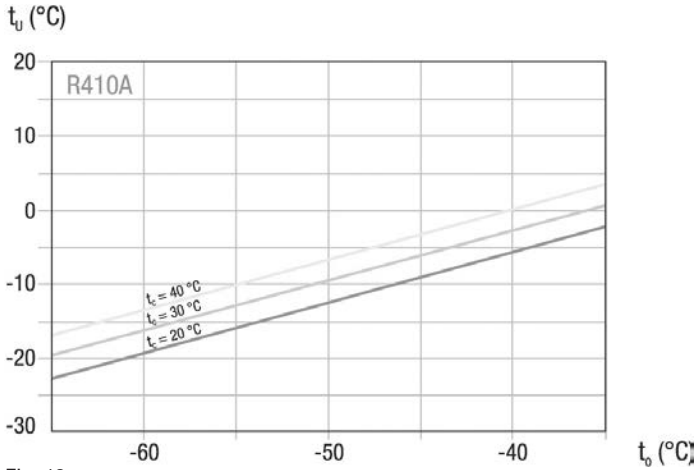

Fig. 13

GB

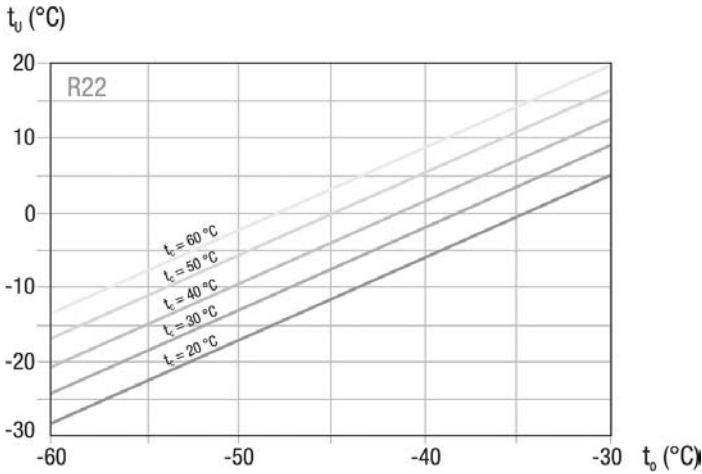

Fig. 14

t_u = Subcooling temperature at the subcooler outlet (FUA)
 t_o = Evaporating temperature

4| Description of functions

The refrigerant suctioned out of the evaporator (20) is compressed by the 4 cylinders of the LP stage (2) to intermediate pressure MP. After that, the superheated refrigerant flows through the intermediate pressure chamber (3), where it is cooled by the liquid subcooler system to reduce the discharge end temperature. The refrigerant then flows through the intermediate pressure line (4) to the electric motor of the compressor for to cool the motor. After this, the refrigerant is suctioned in by the two HP cylinders (5) and compressed to the final pressure.

Liquid subcooler system

The liquid subcooler system consists of the components

- liquid subcooler (plate heat exchanger) (6)
- expansion valve (7)
- sight glass (8)
- solenoid valve (9)
- filter drier (10)

After the refrigerant receiver (15), the liquid line will be splitted into two lines:

Line A leads through the liquid subcooler (6) and the subcooled refrigerant flows to the evaporator (20). Through **Line B** refrigerant is expanding through the expansion valve (7) into the liquid subcooler (6) in order to subcool the refrigerant of line A and through the intermediate pressure line (MP) to cool the superheated refrigerant, which is compressed from low pressure to intermediate pressure chamber (3).

4 | Description of functions

4.1 Two-stage refrigeration cycle with liquid subcooler

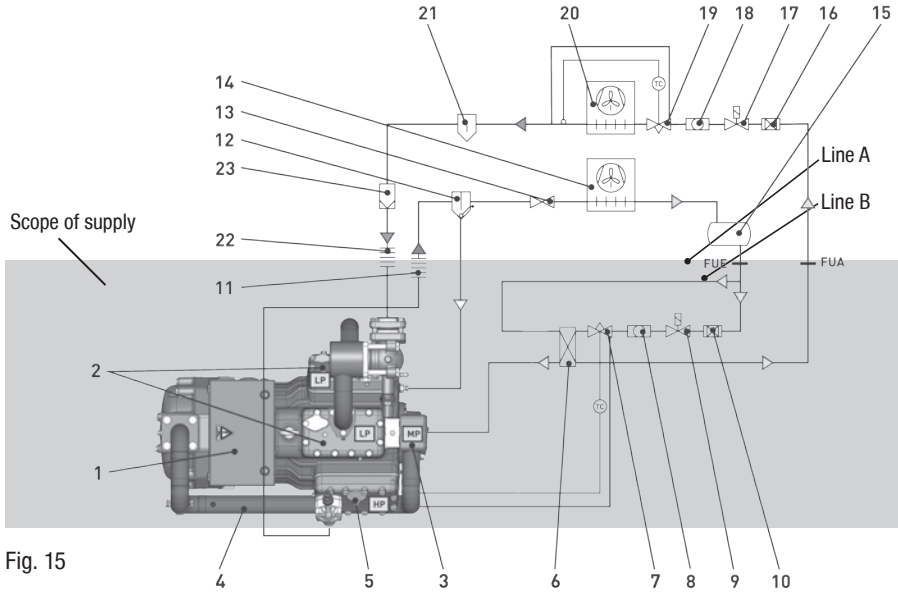

GB

Explanations

- 1 Compressor
- 2 Cylinder LP-stage
- 3 Intermediate pressure chamber MP
- 4 Intermediate pressure line MP
- 5 Cylinder HP-stage
- 6 Liquid subcooler
- 7 Reinjection valve
- 8 Sight glass
- 9 Solenoid valve
- 10 Filter drier
- 11 Damper, pressure line
- 12 Oil separator
- 13 Non-return valve
- 14 Condenser

- 15 Refrigerant receiver
- 16 Filter drier
- 17 Solenoid valve
- 18 Sight glass
- 19 Expansion valve (evaporator)
- 20 Evaporator
- 21 Liquid separator
- 22 Damper, suction line
- 23 Filter suction line

LP = Low pressure
 MP = Intermediate pressure
 HP = High pressure
 FUE = Liquid subcooler, inlet
 FUA = Liquid subcooler, outlet

5| Compressor assembly



INFO

New compressors are factory-filled with inert gas. Leave this service charge in the compressor for as long as possible and prevent the ingress of air. Check the compressor for transport damage before starting any work.

5.1 Storage and transportation



Fig. 16

- Storage at (-30°C) - (+70°C), maximum permissible relative humidity 10% -95 %, no condensation.
- Do not store in a corrosive, dusty, vaporous atmosphere or in a combustible environment.



Fig. 17

- Use transport eyelet.
- Do not lift manually!
- Use lifting gear!

5.2 Setting up



ATTENTION Fittings (e.g. pipe holders, additional units, mounting parts etc.) on the compressor are not permissible!

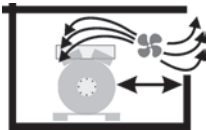

Fig. 18

- Provide adequate clearance for maintenance work.
- Ensure adequate compressor ventilation.



Fig. 19

- Do not use in a corrosive, dusty, damp atmosphere or a combustible environment.

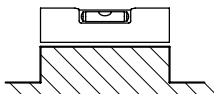

Fig. 20

- Setup on an even surface or frame with sufficient load-bearing capacity.
- Compressor in principle rigidly install.

5 | Compressor assembly

5.3 Installation of the liquid subcooler system (optional version)

Separately enclosed components:

- ① Liquid subcooler
- ② Reinjection valve
- ③ Solenoid valve
- ④ Filter drier
- ⑤ Sight glass
- ⑥ Screw-in sleeve, solder adapter and seals

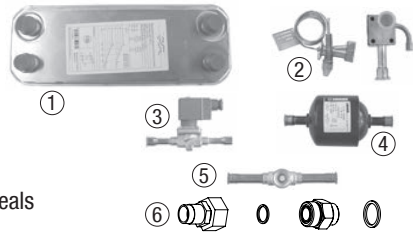

Please check for completeness of parts before beginning installation.

Fig. 21



INFO

Observe manufacturer's instructions!



ATTENTION

To avoid vibration cracks in the subcooler system, the individual components must be mounted directly to the compressor or installed as a decoupled unit!

Assembly:



INFO

The points listed here represent general guidelines and information on how to pipe and connect the subcooler unit. To perform this work technical knowledge and skill as well as proof of a hard-soldering test certificate in accordance with DIN EN 13133 is required.

GB

Pipe connections:

For connections, see dimension diagram Chapter 10.

- System design, piping and necessary support points for the individual components must be carefully planned and carried out.
- Properly insulate liquid subcooler against condensation and heating and the related loss of performance.
- For rigidity reasons, the use of stainless steel pipes with a wall of 1 mm is preferred. The pipes must be free of tension during and after soldering to prevent possible breaks later on.



INFO

Use only suitable hard solder and flux. Solder under an inert gas atmosphere when copper components are to be soldered! The accompanying expansion valve is designed and adjusted for the compressor and the listed refrigerant (sensor charge, nozzle). Only use expansion valves approved and supplied by GEA!



INFO

The intermediate pressure line and intermediate pressure chamber are fully insulated at the factory. To mount the expansion valve, cut the insulation as shown in the marked area in Fig. 22, page 18. Correct sensor placement is marked by an unpainted area on the pipe.

5 | Compressor assembly

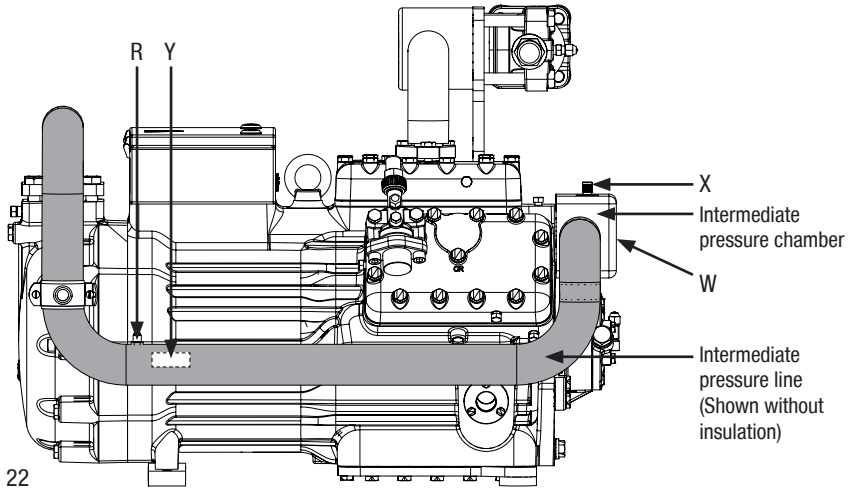

Fig. 22

GB

R	Connection of pressure compensation line for expansion valve	$7/16"$ UNF
W	Refrigerant injection connection	M22 x 1,5
X	Schrader connection for intermedie-pressure gauge	$7/16"$ UNF
Y	Position of temperature sensor / unpainted	

5 | Compressor assembly

5.4 Installation example, liquid subcooler with accessories

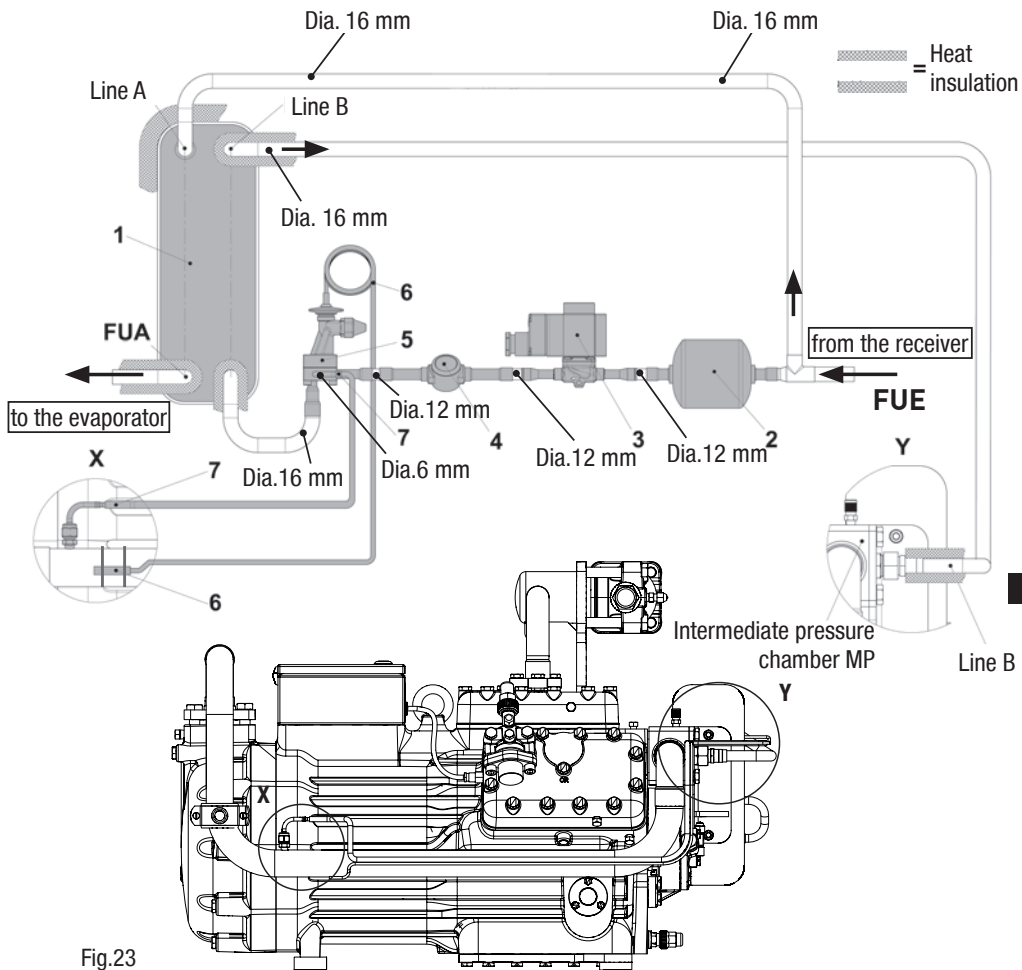

Fig.23

- 1 Liquid subcooler
- 2 Filter drier
- 3 Solenoid valve
- 4 Sight glass

- 5 Expansion valve
- 6 Temp. sensor expansion valve
- 7 Pressure compensation connection

- FUA Liquid subcooler, Outlet
- FUE Liquid subcooler, Inlet



INFO

General notes:

- Sensor lines, wires, etc. should not be attached with cable binders directly to pipes or frames; otherwise, the thin pipes may be worn through. It is better to run them through spiral protective tubes.
- If the compressor will be set up outside, UV-resistant materials should be used.

5 | Compressor assembly

5.5 Factory-installed liquid subcooler system (optional design)

Liquid subcooler, expansion valve, solenoid valve and the sight glass are mounted directly at the compressor, piped and insulated.

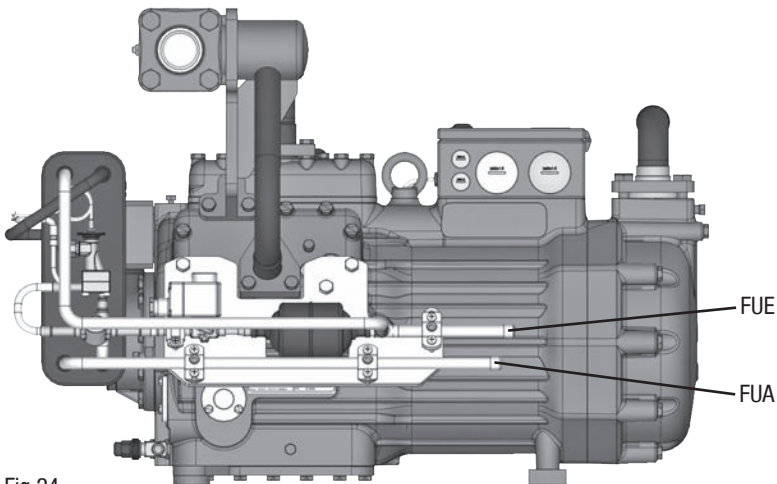

Fig.24

FUE: Liquid subcooler inlet
FUA: Liquid subcooler outlet

GB

5.6 Pipe connections



ATTENTION **Damage possible.**
Superheating can damage the valve.
Remove the pipe supports therefore from the valve for soldering.
Only solder using inert gas to inhibit oxidation products (scale)

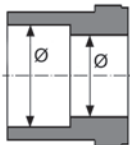

Fig. 25: graduated internal diameter

- The **pipe connections** have graduated inside diameters so that pipes with standart millimetre and inch dimensions can be used.
- The connection diameters of the shut-off valves are rated for maximum compressor output. **The actual required pipe cross section must be matched to the output. The same applies for non-return valves.**



INFO **A soldering suppot for tube diameter 54 mm is mounted to the suction shut-off valve of the compressor.**
A soldering support for tube diameter 2 1/8" accompanies the compressor.

5 | Compressor assembly

5.7 Pipes

- Pipes and system components must be clean and dry inside and free of scale, swarf and layers of rust and phosphate. Only use air-tight parts.
- Lay pipes correctly. Suitable vibration compensators must be provided to prevent pipes being cracked and broken by severe vibrations.
- Ensure a proper oil return.
- Keep pressure losses to an absolute minimum.

5.8 Laying suction and pressure lines



ATTENTION Improperly installed pipes can cause cracks and tears, the result being a loss of refrigerant.



INFO Proper layout of the suction and discharge lines directly after the compressor is integral to the system's smooth running and vibration behaviour.

A rule of thumb: Always lay the first pipe section starting from the shut-off valve **downwards and parallel to the drive shaft**.

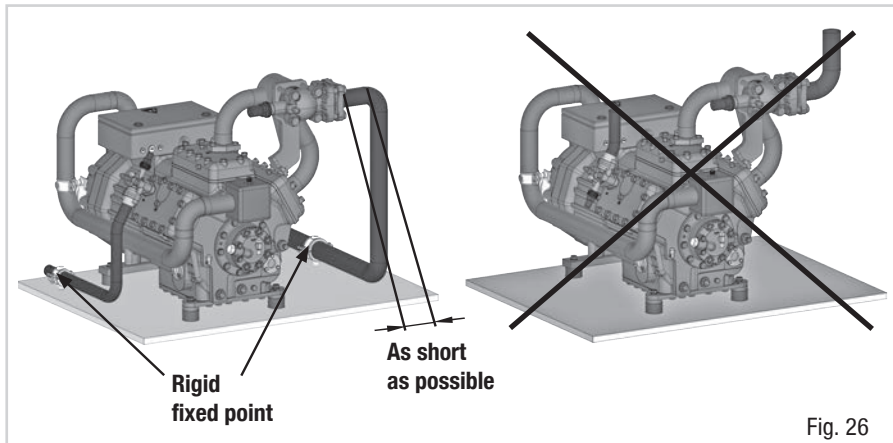

GB

5 | Compressor assembly

5.9 Operating the shut-off valves

- Before opening or closing the shut-off valve, release the valve spindle seal by approx. $\frac{1}{4}$ of a turn counter-clockwise.
- After activating the shut-off valve, re-tighten the adjustable valve spindle seal clockwise.

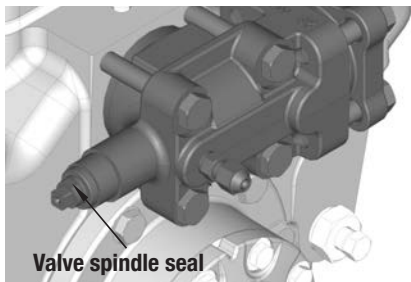

Fig. 27

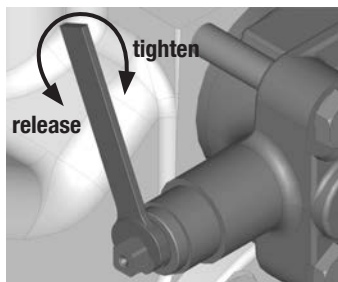

Fig. 28

5.10 Operating mode of the lockable service connections

GB

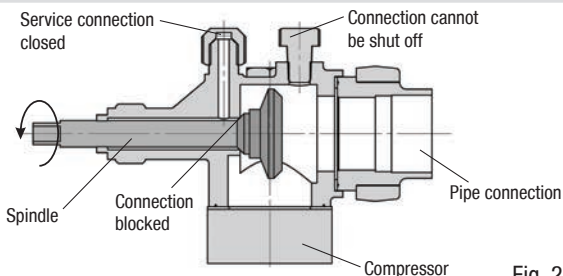

Fig. 29

Opening the shut-off valve:

Spindle: turn to the left (counter-clockwise) as far as it will go.

—> Shut-off valve completely opened / service connection closed.

The connection which cannot be shut off is intended for safety devices.

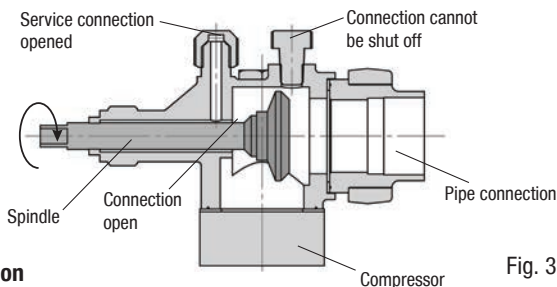

Fig. 30

Opening the service connection

Spindle: Turn $\frac{1}{2}$ - 1 turn to the right clockwise.

—> Service connection opened / shut-off valve opened.

The connection which cannot be shut off is intended for safety devices.

After activating the spindle, generally fit the spindle protection cap again and tighten with 14-16 Nm. This serves as a second sealing feature during operation.

6 | Electrical connection

6 Electrical connection



DANGER

Risk of electric shock! High voltage!

Only carry out work when the electrical system is disconnected from the power supply!



ATTENTION

When attaching accessories with an electrical cable, a minimum bending radius of 3 x the cable diameter must be maintained for laying the cable.



INFO

Connect the compressor motor in accordance with the circuit diagram (see inside of terminal box).

- Use suitable cable entry point of the correct protection type (see name plate) for routing cables into the terminal box. Insert the strain reliefs and prevent chafe marks on the cables.
- Compare the voltage and frequency values with the data for the mains power supply.

Only connect the motor if these values are the same.

6.1 Information for contactor and motor contactor selection

All protection devices and switching or monitoring units must be fitted in accordance with the local safety regulations and established specifications (e.g. VDE) as well as with the manufacturer's information. **Motor protection switches are required!** Motor contactors, feed lines, fuses and motor protection switches must be rated on the basis of the maximum working current (see name plate). For motor protection use a current-dependent and time-delayed overload protection device for monitoring all three phases. Set the overload protection device so that it must be actuated within 2 hours, if there is 1.2 times the max. working current.

GB

6.2 Circuit diagram for part-winding start

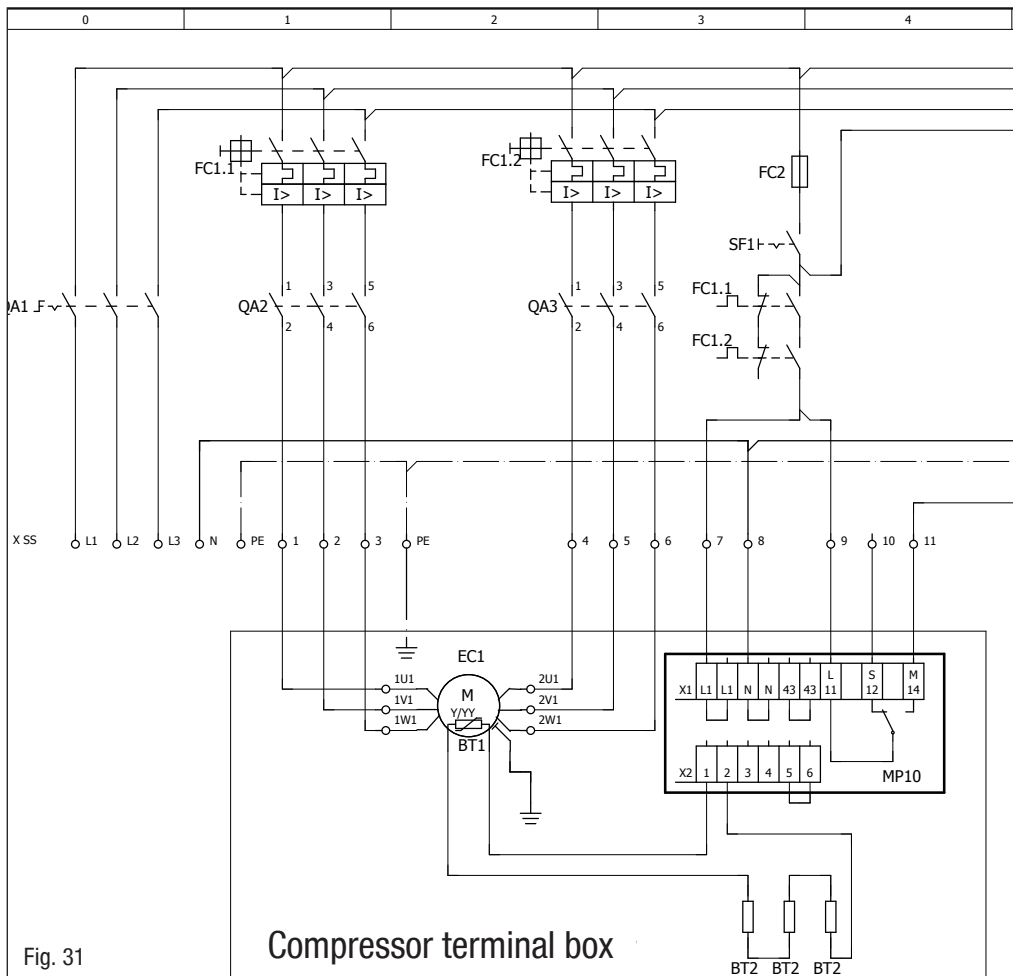

QA1	Main switch
FC1.1	Motor protection switch part winding 1
FC1.2	Motor protection switch part winding 2
FC2	Fuse control current circuit
BP2	High pressure safety monitor
BP3	Safety chain (high/low pressure monitoring)
BP1	Oil differential pressure monitor
SF1	Control voltage switch
BT3	Release switch (thermostat)
QA2	Mains contactor part winding 1
QA3	Mains contactor part winding 2

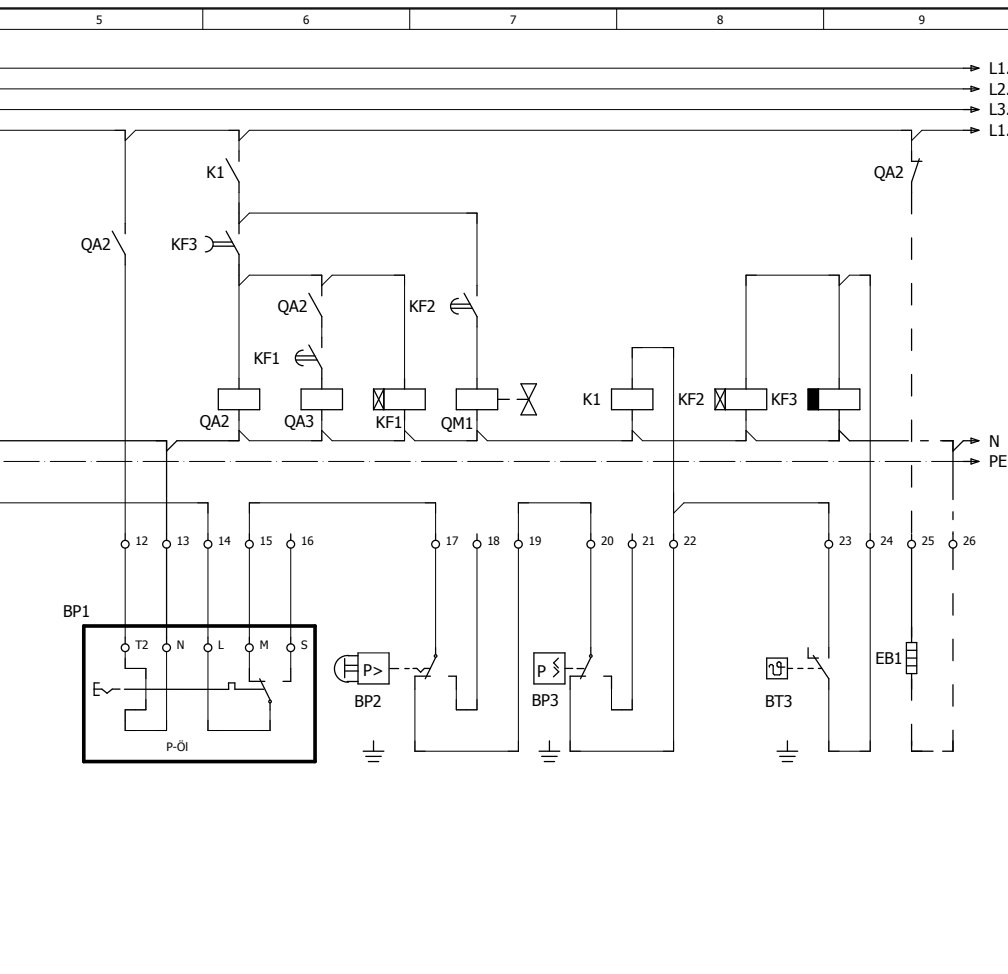

GB

KF1	Delay relay max. 1 s (slow release), part winding 2
KF2	Delay relay max. 20 s (slow release), Open solenoid Y1 (subcooler)
KF3	Delay relay max. 20 s (slow release), compressor switch-off (suction subcooler)
QM1	Solenoid valve intermediate cooler
EC1	Compressor motor
BT1	Cold conductor (PTC sensor)
BT2	Thermal protection thermostat (PTC sensor)
K1	Auxiliary contactor safety chain

09726-06.2018-DGbF

6| Electrical connection

6.3 Standard motor, design for direct or partial winding start

Designation on the name plate	Sticker on the terminal box
Y/YY	

Compressors with this marking are suitable for direct or partial winding start. The motor winding is subdivided into two parts:

Part winding 1 = 50% and part winding 2 = 50%.

This winding division reduces the start-up current needed for a part winding start to approx. 50% of that for a direct start.



INFO

A mechanical unloaded start with bypass solenoid valve is not required.

The motor is wired for direct start (YY) at the factory. For part winding start Y/YY the bridges must be removed and the motor feed line connected according to the circuit diagram:

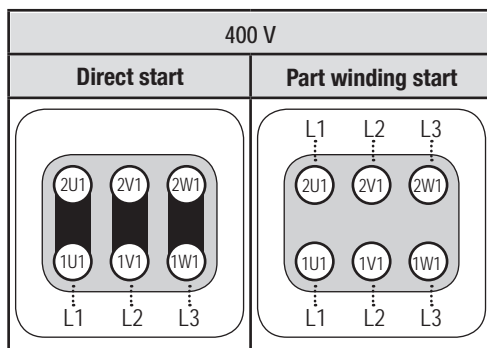

ATTENTION

Failure to do this results in opposed rotary fields and results in damage to the motor. After the motor starts up via partial winding 1, partial winding 2 must be switched on after a maximum delay of one second. Failure to comply can adversely affect the service life of the motor.

6| Electrical connection

6.4 Electronic trigger unit MP10

The compressor motor is fitted with cold conductor temperature sensors (PTC) connected to the electronic trigger unit MP 10 in the terminal box. Readiness to operate is signalled by the H3 LED (green) after the power supply is applied. In the case of excess temperature in the motor winding, the unit switches off the compressor and the H1 LED lights red.

The hot gas side of the compressor can also be protected against overtemperature using a thermal protection thermostat (accessory). The H2 LED (red) is provided for the protection function.

The unit trips when an overload or inadmissible operating conditions occur. Find and remedy the cause.



INFO

The unit has a restart prevention device. After you have rectified the fault, interrupt the mains voltage. This unlocks the restart prevention device and the LEDs H1 and H2 go out.

6.5 Connection of the trigger unit MP10



INFO

Connect the trigger unit MP10 in accordance with the circuit diagram. Protect the trigger unit with a delayed-action fuse (F) of max. 4 A. In order to guarantee the protection function, install the trigger unit as the first element in the control power circuit.

GB

Temperature monitoring connections:

- Motor winding: Terminals 1 - 2
- Thermal protection thermostat: Terminals 3 - 4
- Restart prevention: Terminals 5 - 6



ATTENTION

Terminals 1 - 6 on the trigger unit MP 10 and terminals PTC 1 and PTC 2 on the compressor terminal board must not come into contact with mains voltage. This would destroy the trigger unit and PTC sensors. The supply voltage at L1-N (+/- for DC 24 V version) must be identical to the voltage at terminals 11, 12, 14 and 43.

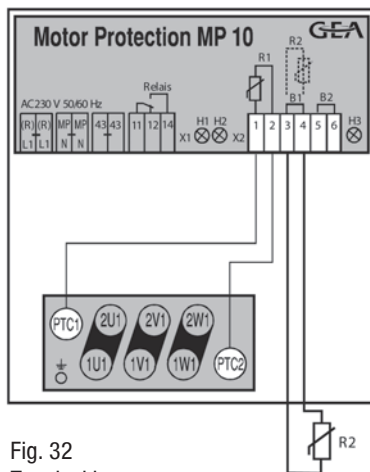

Fig. 32
Terminal box

6| Electrical connection

6.6 Function test of the trigger unit MP10

Before start-up, troubleshooting or making changes to the control power circuit, check the functionality of the trigger unit:

Pos	Procedure	LED H1 red	LED H2 red	LED H3 green
1	<ul style="list-style-type: none">• Interrupt power supply (L1 or S1)• Release the motor temperature sensor connection (1 or 2)• Release the hot gas temperature sensor (if installed) (3 or 4)	OFF	OFF	OFF
2	<ul style="list-style-type: none">• Restore the power supply (L1 or S1)• Function check of motor temperature sensor: operational• Function check of hot gas temperature sensor: operational	ON	ON	ON
3	<ul style="list-style-type: none">• Interrupt power supply again (L1 or S1)• Reconnect terminals 1 or 2 and/or 3 or 4	OFF	OFF	OFF
4	<ul style="list-style-type: none">• Restore the power supply (L1 or S1):• MP10 is operational again	OFF	OFF	ON

The compressor and the trigger unit MP10 are operational when the H3 LED (green) lights.

6| Electrical connection

6.7 Oil sump heater (accessories)

When the compressor is at a standstill, refrigerant diffuses into the lubricating oil of the compressors housing, depending on pressure and ambient temperature. This reduces the lubricating capacity of the oil. When the compressor starts up, the refrigerant contained in the oil evaporates out through the reduction in pressure. The consequences can be foaming and migration of the oil, causing oil shocks under certain circumstances.

Operation: The oil sump heater operates when the compressor is at a standstill. When the compressor starts up, the oil sump heater switches off again automatically.

Connection: The oil sump heater must be connected via an auxiliary contact (or parallel wired auxiliary contact) of the compressor contactor to a separate electric circuit.

El. data: 230 V - 1 - 50/60 Hz, 140 W.

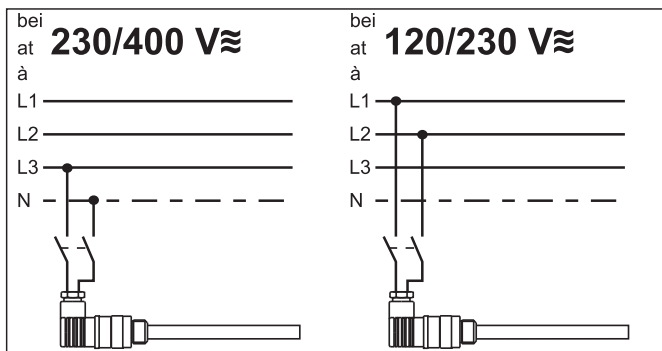

Fig. 33



ATTENTION The oil sump heater must not be connected to the electrical circuit of the safety control chain.

GB

7 | Commissioning

7.1 Preparations for start-up



INFO

In order to protect the compressor against inadmissible operating conditions, high pressure and low pressure pressostats are mandatory on the installation side.

The compressor has undergone trials in the factory and all functions have been tested. There are therefore no special running-in instructions.

Check the compressor for transport damage!

7.2 Pressure strength test

The compressor has been tested in the factory for pressure integrity. If however the entire system is to be subjected to a pressure integrity test, this should be carried out in accordance with EN 378-2 or a corresponding safety standard **without the inclusion of the compressor.**

7.3 Leak test



DANGER

Risk of bursting!

The compressor must only be pressurised using nitrogen (N₂). Never pressurise with oxygen or other gases!

The maximum permissible overpressure of the compressor must not be exceeded at any time during the testing process (see name plate data)! Do not mix any refrigerant with the nitrogen as this could cause the ignition limit to shift into the critical range.

- Carry out the leak test on the refrigerating plant in accordance with EN 378-2 or a corresponding safety standard, while always observing the maximum permissible overpressure for the compressor.

7.4 Evacuation



ATTENTION

Do not start the compressor if it is under vacuum. Do not apply any voltage - even for test purposes (must only be operated with refrigerant).

Under vacuum, the spark-over and creepage current distances of the terminal board connection bolts shorten; this can result in winding and terminal board damage.

- First evacuate the **system** and then include **the compressor in the evacuation process.**
- Relieve the compressor pressure.
- Open the suction and pressure line shut-off valves.
- Evacuate the suction and discharge pressure sides using the vacuum pump.
- At the end of the evacuation process, the vacuum should be < 1.5 mbar when the pump is switched off.
- Repeat this process as often as is required.

In addition to the suction or high pressure side, the intermediate pressure area of the compressor must also be evacuated (use connection X, see page 18, fig. 22). The solenoid valve of the subcooling system (page 19, fig. 23, item 3) must be opened.

7 | Commissioning

7.5 Refrigerant charge



CAUTION Wear personal protective clothing such as goggles and protective gloves!

- Make sure that the suction and pressure line shut-off valves are open.
- With the compressor switched off, add the liquid refrigerant directly to the condenser or receiver, breaking the vacuum.
- **Pay attention to adequate refrigerant fill before starting up the compressor.**
During operation, refrigerant must be free of bubbles in sight glasses 1 and 2 of the liquid subcooler.
- If the refrigerant needs topping up after starting the compressor, it can be topped up in vapour form on the suction side, or, taking suitable precautions, also in liquid form at the inlet to the evaporator.



ATTENTION

- **Avoid overfilling the system with refrigerant!**
- **To avoid shifts in concentration, zeotropic refrigerant blends must always only be filled into the refrigerating plant in liquid form.**
- **Do not pour liquid coolant through the suction line valve on the compressor.**
- **It is not permissible to mix additives with the oil and refrigerant.**

GB

7.6 Start-up



WARNING Ensure that both shut-off valves are open before starting the compressor!

- Check that the safety and protection devices (pressure switch, motor protection, electrical contact protection measures, etc.) are all functioning properly.
- Switch on the compressor and allow to run for a minimum of 10 min.
- **Check the oil level by:** The oil must be visible in the sightglass.



ATTENTION If larger quantities of oil have to be topped up, there is a risk of oil hammer effects.
If this is the case check the oil return!

7 | Commissioning

7.7 Avoiding slugging



ATTENTION Slugging can damage the compressor and cause refrigerant to leak.

To prevent slugging:

- The complete refrigeration system must be properly designed.
- All components must be compatibly rated with each other with regard to output (particularly the evaporator and expansion valves).
- Suction gas superheat at the compressor input **should be min. 7 - 10 K.** (check the setting of the expansion valve).
- The system must reach a state of equilibrium.
- When selecting the evaporator expansion valve, pay attention to correction factors for liquid subcooling. **Avoid transfer of refrigerant into the compressor when the system is at a standstill.**
- The use of a liquid separator is recommended.



ATTENTION To avoid liquid shocks on the HP stage, the expansion valve may only be opened approx. 15-20 seconds after the compressor is switched on (full load operation).

At compressor shut-down:

Close the solenoid valve approx. 15 - 20 seconds before the compressor is switched off.

8 | Maintenance

8.1 Preparation



WARNING

Before starting any work on the compressor:

- Switch off the compressor and secure it to prevent a restart.
- Relieve compressor of system pressure.
- Prevent air from infiltrating the system!

After maintenance has been performed:

- Connect safety switch.
- Evacuate compressor.
- Release switch lock.

8.2 Work to be carried out

In order to guarantee optimum operational reliability and service life of the compressor, **we recommend** carrying out servicing and inspection work at regular intervals:

● Oil change:

- not mandatory for factory-produced series systems.
- for field installations or when operating near the application limit: for the first time after 100 to 200 operating hours, then approx. every 3 years or 10,000 - 12,000 operating hours. Dispose of used oil according to the regulations; observe national regulations.

- **Annual checks:** Oil level, leak tightness, running noises, pressures, temperatures, function of auxiliary devices such as oil sump heater, pressure switch.

GB

8.3 Recommended spare parts

HGZ7 / ...	1620-4	1860-4	2110-4
Designation	Item No.	Item No.	Item No.
Set of gaskets kit		80197	
Valve plate kit low pressure side LP		80193	
Valve plate kit high pressure side HP		80194	
Piston-connecting rod kit	08995	08996	80112
Piston kit	80042	80048	80106
Connecting rod kit		80306	
Oil pump kit		80116	
Oil sump heater kit		08426	

Only use genuine GEA spare parts!

8 | Maintenance

8.4 Replacing the valve plates

The compressors are divided into an LP and an HP compressor stage. Different valve plate designs are required because of the different ducts in the individual compressor stages.



WARNING The valve plates have been fitted with safety bolts to prevent any confusion. The safety bolts engage in the corresponding bores on the cylinder heads, **the safety bolts must not be removed!**

Installation of the valve plates:

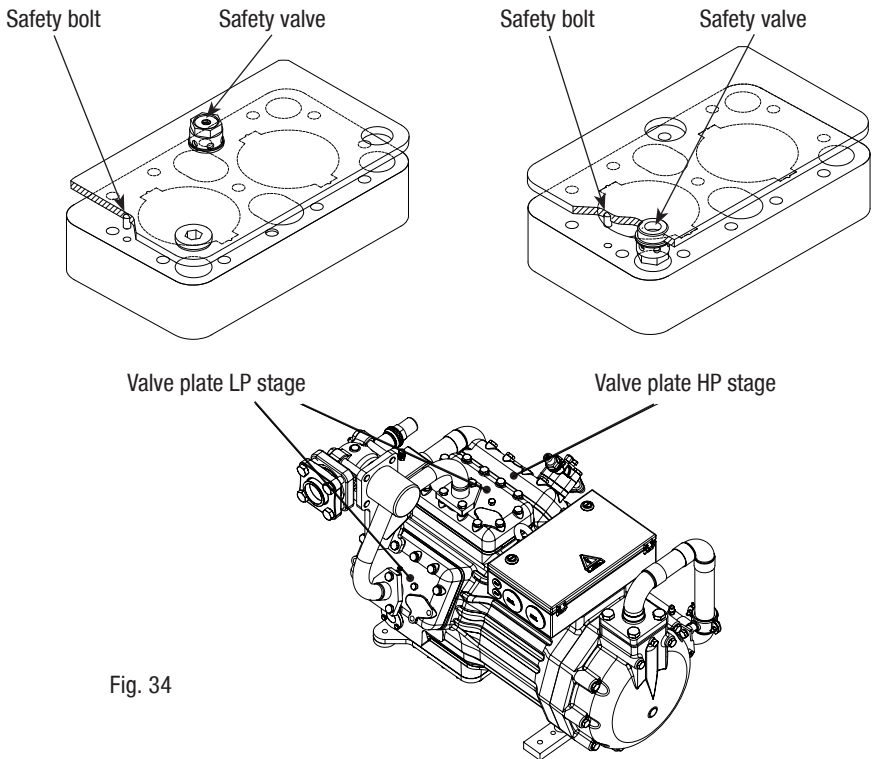

Fig. 34

8 | Maintenance

8.5 Extract from the lubricants table

The oil type filled as standard in the factory is marked on the **name plate**. **This oil type should be used as a preference**. Alternatives are stated in the extract from our lubricants table below.

Refrigerants	GEA standard oil types	Recommended alternatives
HFkW (e.g. R404A, R407C)	Fuchs Reniso Triton SE 55	Fuchs Reniso Triton SEZ 32 Esso/Mobil EAL Arctic 46 Sunoco Suniso SL 46 Texaco Capella HFC 55
HFCKW (e.g. R22)	Fuchs Reniso SP 46	Fuchs Reniso SP 32 BP Energol LPT 46 Sunoco Suniso 3,5 GS Texaco Capella WF 46

8.6 Decommissioning

Close the shut-off valves on the compressor. Drain the refrigerant (it must not be discharged into the environment) and dispose of it according to the regulations. When the compressor is depressurised, undo the fastening screws of the shut-off valves. Remove the compressor using an appropriate hoist. Dispose of the oil inside in accordance with the applicable national regulations.

GB

8.7 Accessories

Available accessories can be found on the Internet at www.gea.com.

9| Technical data

Type	No. of cylinders		Displacement				Electrical data ^③			Connections ¹⁾		Oil charge
			50 Hz (1450 rpm) LP HP	60 Hz (1740 rpm) LP HP	Voltage ^①	Max. operating current ^②	Max. power consumption ^②	Starting current (rotor locked) ^②	Weight ²⁾	Discharge line DV	Suction line SV	
HGZ7/1620-4			m ³ /h	m ³ /h		A	kW	A	kg	mm (inch)	mm (inch)	Ltr.
						*PW 1+2		*PW1/PW 1+2				
HGZ7/1860-4	6		93,7 / 46,9	112,5 / 56,2	④	50	27,0	175 / 269	294			
			107,6 / 53,8	129,1 / 64,6	④	55	30,0	175 / 269	290	35 (1 3/8)	54 (2 1/8)	4,5
HGZ7/2110-4			122,4 / 61,2	146,9 / 73,5	④	65	36,0	232 / 357	288			

* PW = Part Winding, motors for part winding starting

1 = 1. part winding, 2 = 2. part winding

1) For solder connections 2) in standard design

LP = Low pressure stage HP = High pressure stage

Oil sump heater: 230V -1- 50/60 Hz 140 W

① Tolerance (± 10%) relative to the mean value of the voltage range.

② Take account of the max. operating current / max. power consumption for design of fuses, supply lines and safety devices.

③ All specifications are based on the average of the voltage range

④ 380-420 V Y/Y -3- 50 Hz PW, 440-480 V Y/Y -3- 60 Hz PW

> Winding ratios: 50% / 50 %

10|Dimensions and connections

10.1 Compressor in standard design

Intermediate pressure mixed line mounted and insulated.
 (Liquid subcooler with accessories as an extra item)

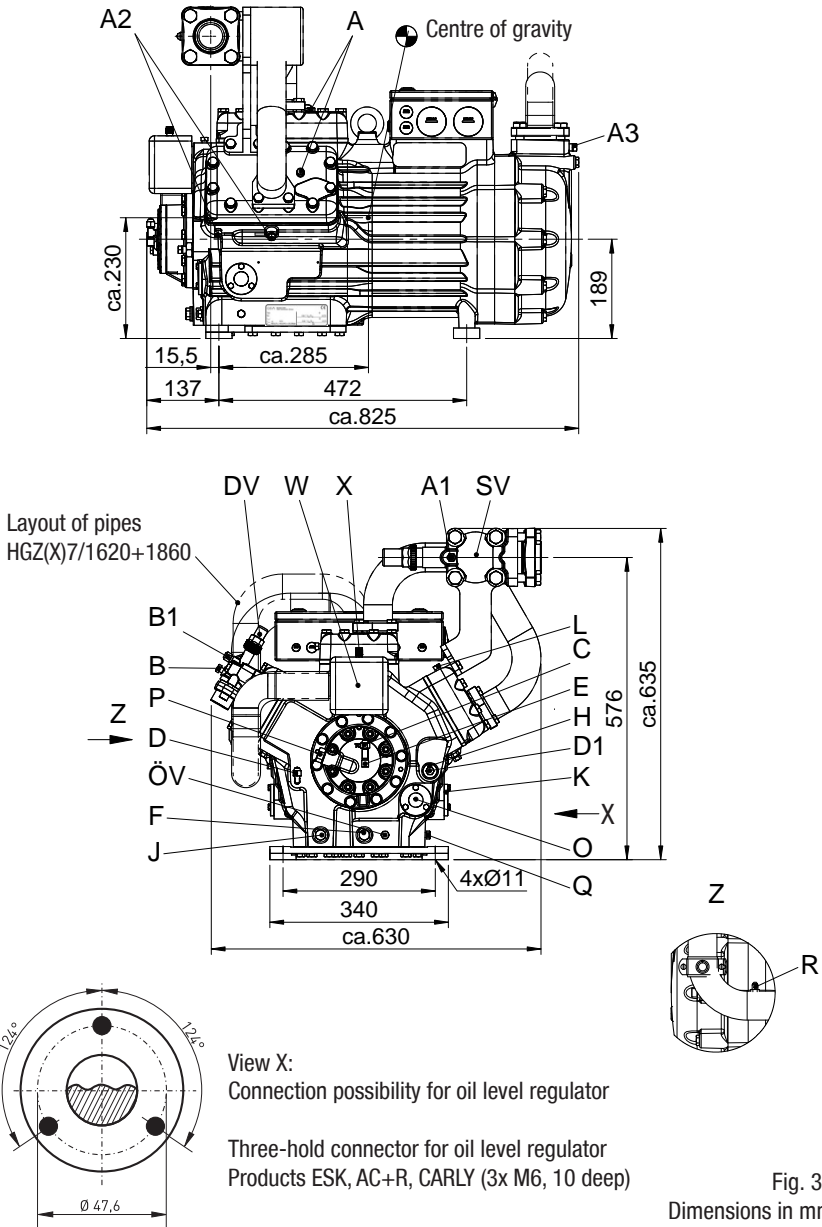

GB

09726-06.2018-DGbF

Fig. 35
 Dimensions in mm

10|Dimensions and connections

10.2 Compressor in optional design

(Liquid subcooler with accessories attached directly to the compressor)

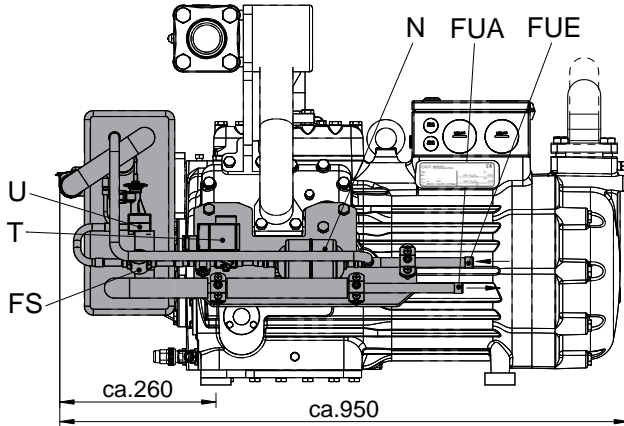

GB

Layout of pipes

HGZ(X)7/1620+1860

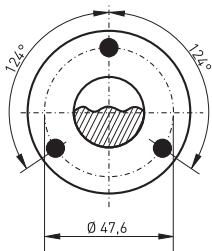
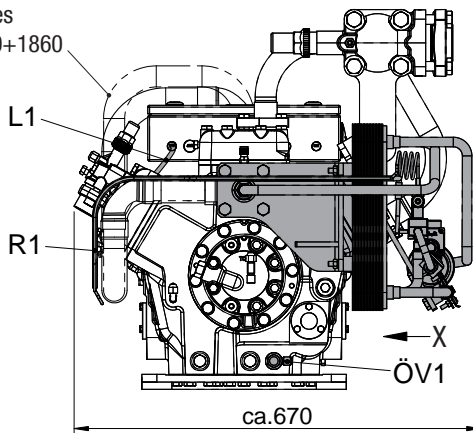

View X:

Connection possibility for oil level regulator

Three-hole connector for oil level regulator
Products ESK, AC+R, CARLY (3x M6, 10 deep)

Fig. 36
Dimensions in mm

09726-06.2018-DGbF

10|Dimensions and connections

SV	Suction line	see technical data, Chapter 9	
DV	Discharge line		
FUE	Liquid subcooler IN		Ø 16 mm - 5/8"
FUA	Liquid subcooler OUT		Ø 16 mm - 5/8"
A	Connection suction side, not lockable		1/8" NPTF
A1	Connection suction side, lockable		7/16" UNF
A2	Connection intermediate pressure, not lockable		1/8" NPTF
A3	Connection intermediate pressure, not lockable		1/4" NPTF
B	Connection discharge side, not lockable		1/8" NPTF
B1	Connection discharge side, lockable		7/16" UNF
C	Connection oil pressure safety switch OIL		7/16" UNF
D	Connection oil pressure safety switch LP		7/16" UNF
D1	Connection oil return from oil separator		1/4" NPTF
E	Connection oil pressure gauge		7/16" UNF
F	Oil drain		M22 x 1,5
FS	Sight glass liquid line		Ø 12 mm
H	Oil charge plug		M22 x 1,5
J	Oil sump heater (accessories)		M22 x 1,5
K	Sight glass		-
L	Connection thermal protection thermostat		1/8" NPTF
L1	Thermal protection thermostat		1/8" NPTF
N	Filter drier		Ø 12 mm
O	Connection oil level regulator		see view X
ÖV	Connection oil service valve		1/4" NPTF
ÖV1	Oil service valve		7/16" UNF
P	Connection oil differential pressure sensor		M20 x 1,5
Q	Connection oil temperature sensor		1/8" NPTF
R	Connection of pressure compensation line for expansion valve		7/16" UNF
R1	Pressure compensation line for expansion valve		Ø 6 mm
T	Solenoid valve		Ø 12 mm
U	Expansion valve - refrigerant-dependent		Ø 12 mm
W	Connection refrigerant injection		M22 x 1,5
X	Connection for Schrader valve for intermediate pressure manometer		7/16" UNF

GB

11| Declaration of installation

DECLARATION OF INSTALLATION

for using the compressors within the European Union
(in accordance with Machinery Directive 2006/42/EC)

The manufacturer: GEA Bock GmbH, Benzstraße 7
72636 Frickenhausen, Tel.: 07022/9454-0

hereby declares that the refrigerating compressor **HGZ7** complies with the basic requirements of Appendix II 1B of the Machinery Directive 2006/42/EC.

Applied harmonised standard:

EN 12693:2008 and the corresponding standards referenced

A partly completed machine may only be put into operation when it has been established that the machine, into which the partly completed machine is to be installed, conforms to the regulations of the Machinery Directive (2006/42/EC).

The manufacturer undertakes to transmit electronically the special documentation required by individual states for partly completed machinery on request.

The special technical documentation required for partly completed machinery has been created in accordance with Appendix VII Part B.

Person responsible for documentation is: Alexander Layh, Benzstraße 7, 72636 Frickenhausen.



Frickenhausen, 2017-09-04

i.A. Alexander Layh,
Head of Compression
Commercial Piston Compressors

GB

11 | Declaration of conformity

PED - CLASSIFICATION

(as per EU Pressure Equipment Directive 2014/68/EU)

DECLARATION OF CONFORMITY

for use of the compressors within the European Union
(as per EU Pressure Equipment Directive 2014/68/EU)

We hereby declare that piping of the refrigerant compressors

HGZX7/2110-4 R404A,
HGZX7/2110-4 R448A/R449A
HGZX7/2110-4 R410A
HGZ7/2110-4 R22

agrees with the Pressure Equipment Directive 2014/68/EU dated 15 May 2014.

Valid for Category I piping

Evaluation procedure module A

The other parts of the piping fall under article 3§3 of the
Guideline and correspond to good engineering practice



Frickenhausen, 2017-09-04

i.A. Alexander Layh,
Head of Compression
Commercial Piston Compressors

GB

12| Service

Dear customer,

GEA compressors are top-quality, reliable and service-friendly quality products.

If you have any questions about installation, operation and accessories, please contact our technical service or specialist wholesaler and/or our representative. The GEA service team can be contacted by phone with a **toll-free hotline 00 800 / 800 000 88** or via **e-mail: info@gea.com**.

Yours faithfully

GEA Bock GmbH

Benzstraße 7

72636 Frickenhausen

Germany



We live our values.

Excellence • Passion • Integrity • Responsibility • GEA-versity

GEA Group is a global engineering company with multi-billion euro sales and operations in more than 50 countries. Founded in 1881, the company is one of the largest providers of innovative equipment and process technology. GEA Group is listed in the STOXX® Europe 600 index.

GEA Bock GmbH
Benzstraße 7
72636 Frickenhausen, Germany

Phone +49 (0)7022 9454-0
Fax +49 (0)7022 9454-137

info@gea.com
gea.com