

三相直流变频系列

Three-phase DC inverter series

驱动板 HMD3W-7* 规格书

Driver Board HMD3W-7* Specification

(191120V2.3)



承认	审核	编制
		

珠海恒途电子有限公司 电话：

0756-3666118 传真：0756-

3666181 (转 816)

 网址：<http://www.growthway.com.cn>

地址：广东省珠海市高新区南方软件园 B1 座 3 楼 1、3 单元



目录

Content

1、	综述 overview.....	1
2、	驱动控制器参数 drive controller parameters.	2
3、	系统框图 system block diagram.....	3
4、	基本特点 basic features.....	3
5、	功能描述 functional description.....	5
6、	故障表 fault table.....	8
6.1	驱动板故障指示灯 driver board fault indicator.....	8
6.2	故障判断条件和停机时长 fault judgment conditions and downtime.....	9
6.3	故障排查方法 troubleshooting method.....	10
7、	驱动板接口定义 driver board interface definition.....	12
8、	安装尺寸 mounting dimensions.....	13
9、	通讯接口 communication interface.....	14
10、	可选择配件 optional accessories.	15
11、	接线图 wiring diagram.....	16
12、	运行电流波形 running current waveform.	17



1、综述

Overview

HMD3W-7*系列型号控制器是专为空调直流变频压缩机/交流变频压缩机而设置的驱动控制器。自身集成了滤波、整流桥、电容、开关电源、充电回路、DSP 芯片控制电路、PIM 模组、通讯电路。用户使用只需外接一个电抗就可以使用。

HMD3W-7* series model controllers are specially designed for air conditioner DC inverter compressors/AC inverter compressors. It integrates filtering, rectifier bridge, capacitor, switching power supply, charging circuit, DSP chip control circuit, PIM module, and communication circuit. Users can use it with only an external reactance.

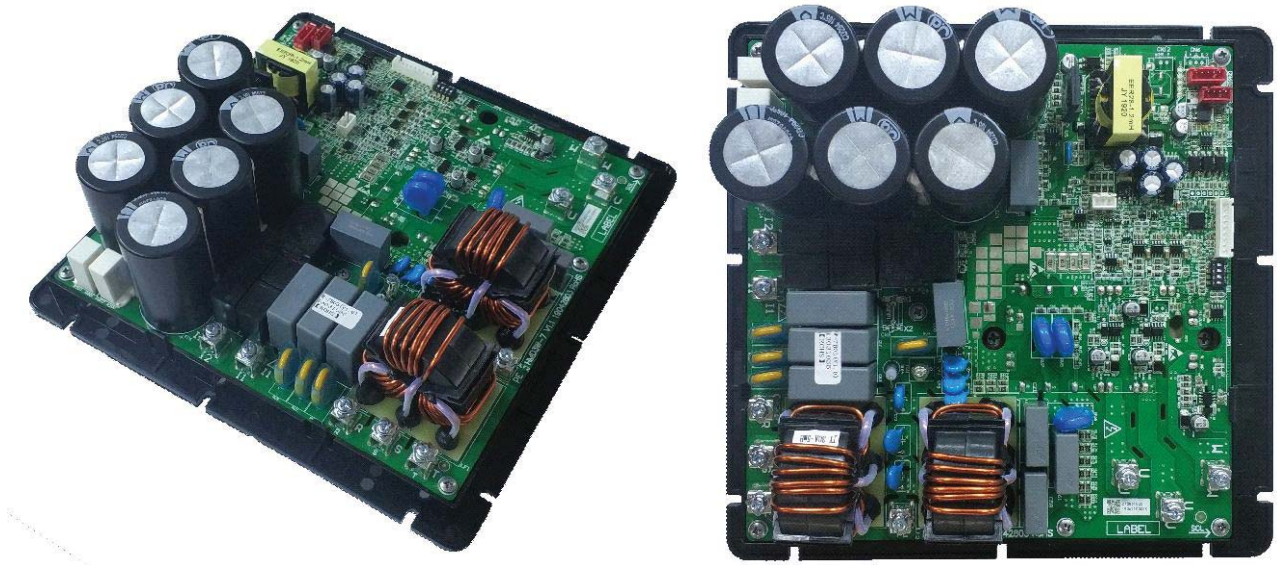

2、驱动控制器参数 Drive controller parameters

序号 No.	项目 Item	规格 Specification
1	额定工作电压 Rated voltage (V)	三相 AC380V (不需 N 零线) Three-phase AC 380V (No need N / neutral)
2	工作电压范围 Operating voltage range (V)	AC320V~AC 460V
3	工作电源频率 Working power frequency (Hz)	50/60±5%Hz
4	最大输入功率 Max power input (W) 注 NOTE ₁	13,000W
5	最大输入电流有效值 Maximum input current RMS (Arms) 注 NOTE ₁	25Arms
6	输出机械频率范围 Output mechanical frequency range (rps) 注 NOTE ₂	15~120rps
7	压缩机驱动方式 Compressor drive mode	无位置传感器 180°正弦波控制 180° sensorless sinusoidal control
8	PWM 载波频率 PWM Carrier frequency (KHz)	5KHz
9	效率 Efficiency η	97%
10	通讯方式 communication method	RS485 接口 RS485 interface
11	压缩机预热功能 Compressor preheating function	有 (暂无) Yes (developing)
12	显示方式 Display method	红、绿、黄 3 个 LED 指示灯 Red, green, yellow 3 LED lights
13	使用环境 Use environment (°C)	-25~+70°C 相对湿度 ≤90%RH (无凝露) Relative humidity ≤90%RH (no condensation)
14	贮存环境 Storage environment (°C)	-40~+85°C 相对湿度 ≤95%RH (无凝露) Relative humidity ≤95%RH (no condensation)

- 注 1：由于受环境温度、散热情况等因素影响，高温情况下需降额使用；
Note 1: Due to factors such as ambient temperature and heat dissipation, derating is required.
- 注 2：输出机械频率范围取决于不同的压缩机。
Note 2: The output mechanical frequency range depends on different compressors.



3、系统框图 System Block Diagram

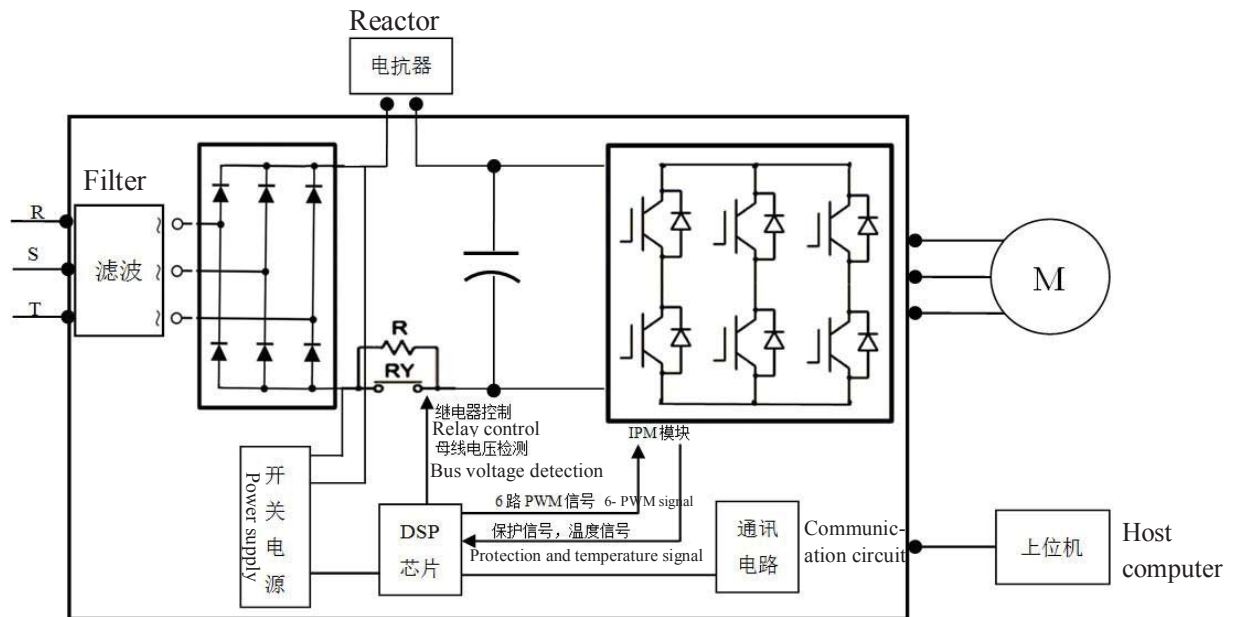

4、基本特点 Basic Features

- 1、自主研发的先进成熟的压缩机驱动方案并结合多年的调试经验，提供 5 个常用压缩机参数，可在 7 个工作日之内完成新产品变频驱动部分的开发；

Independently develop advanced and mature compressor drive solutions, combined with years of debugging experience, By providing 5 compressor parameters, we can complete the development of new product variable frequency drive in 7 working days;

- 2、驱动采用无传感器的 SVPWM 正弦波控制，可以有效减小高次谐波成分、电机振动、转矩波动及噪音；

The drive uses sensorless SVPWM sine wave control to effectively reduce high harmonic components, motor vibration, torque ripple and noise;

- 3、压缩机启动采用闭环启动控制方案，可以保证压缩机的平稳启动，减小压缩机的启动电流，减小对电网的冲击；

The compressor starts with a closed-loop starting control scheme, which can ensure the smooth start of the compressor, reduce the starting current of the compressor, and reduce the impact on the grid.



4、弱磁控制&MTPA 控制方案，可以提高压缩机运行频率范围；

Field weakening control & MTPA control scheme can increase the operating frequency range of the compressor;

5、控制策略使用双闭环反馈方案，外环（速度环）确保机组频率稳定运行；内环（电流环）确保机组实时输出精确的转矩；

The control strategy uses a double closed-loop feedback scheme. The outer loop (speed loop) ensures stable operation of the unit frequency; the inner loop (current loop) ensures that the unit outputs accurate torque in real time;

6、超宽电压运行范围，可在三相 320V~460V 的电压范围内稳定运行；

Wide operating voltage range, stable operation in a voltage range of three-phase 320V ~ 460V;

7、驱动方案实现了高效能、小型化、集成度高等特点，方便生产、测试、维护；

The drive scheme achieves high energy efficiency, miniaturization and high integration, which is convenient for production, testing and maintenance.

8、具备多种保护功能（欠压、过压、过流、过温等），且使用快速实现各种数字信号处理算法的 DSP 芯片，让所有保护功能得到快速响应，以保证系统高效、可靠运行。

With a variety of protection functions (undervoltage, overvoltage, overcurrent, high temperature, etc.), and the use of fast DSP chip, all protection functions are quickly responded to ensure reliable operation of the system.



5、功能描述 Functional description

5.1 软启动控制 Soft-start control

机组上电，驱动板通过 PTC 电阻和整流桥软启动给电解电容充电，开关电源开始工作，驱动板芯片开始工作；驱动板得电芯片开始工作后，指示灯先全亮 5s，等待上位机发送开机指令。延时 12s 后，驱动板判断母线电压，满足条件后，延时吸合充电继电器；继电器一旦吸合，则不会主动关断，直到出现输入电源异常或母线电压过低，继电器控制电源掉电。充电回路故障无故障代码。

When the unit is powered on, the drive board charges the electrolytic capacitor through the PTC resistor and the rectifier bridge soft start, the switching power supply starts to work, and the drive board chip starts to work; after the drive board is powered on, the indicator light will be on for 5 seconds and wait for the host computer to send Boot instruction. After a delay of 12s, the driver board judges the bus voltage, and when the conditions are met, the charging relay will be delayed; once the relay is activated, it will not actively shut down until the input power is abnormal or the bus voltage is too low, and the relay control power supply is powered off. There is no fault code for charging circuit failure.

5.2 待机 Standby

当上位机发过来的设定频率等于 0 或小于最小运行频率 f_{min} 时，驱动板处于待机状态。

若驱动板无故障，待机时绿灯闪烁（每接收到上位机发送过来数据闪烁一次），启动成功后运转时红灯闪烁（每接收到上位机发送过来数据闪烁一次）；

若驱动板有故障，则故障将会传递到主控并显示（遵循驱动与主控的通信协议），同时驱动板有相应的故障指示灯（参考第 6 章故障表）与相应的动作状态。

When the set frequency sent by the host computer is equal to 0 or less than the minimum operating frequency (f_{min}), the drive board is in the standby state.

If the drive board is not faulty, the green light flashes during standby (flashing once every time data sent from the host computer is received), and red light flashes when running after successful startup (flashing once every time data sent from the host computer is received);

If the drive board is faulty, the fault will be transmitted to the main control and displayed (following the communication protocol between the drive and the main control). At the same time, the drive board has a corresponding fault indicator (refer to Chapter 6 Fault Table) and corresponding action status.

5.3 压缩机绕组加热 Heating the compressor windings

当上位机发过来绕组加热命令后，继电器吸合。按上位机命令，在 U、V、W 三相输出相应功率（可输出的最大绕组加热功率为 200W），此时红灯闪烁（每接收到上位机发过来的数据时就闪烁一次）。When the host computer sends the winding heating command, the relay is closed. According to this command, the corresponding power is output in the three phases U, V, W (the maximum winding heating power output can be 200W), and the red light flashes (flashing once every time data from the host computer is received).

技术专用章

5.4 压缩机运行 Compressorrunning

当上位机发过来的设定频率 \geq 最小运行频率 f_{min} 时，驱动板会控制压缩机启动运行至设定频率。在不同的频段升频加速度如下：

When the set frequency sent by the host computer is greater than the minimum operating frequency (f_{min}), the drive board will control the compressor to start running to the set frequency. The frequency raising speed in different range is as follows

在不同的频段升频加速度按如下控制 Raising frequency control：

运行频段 Frequency band	升频速率 Speed
0~10 rps	1rps/S
10~60rps	2rps/S
60~75rps	1rps/S
>75rps	0.5 rps/S

不同目标能力降频速率按如下控制 Down frequency control：

目标频率 Target frequency	降频速率 Speed
$\geq f_{min}$	2rps/S
$< f_{min}$	8rps/S

5.5 停机 Shutdown

接收到上位关机指令（设定频率 $<$ 最低频率 f_{min} ）后，压缩机停止运行，切换为待机绿灯闪烁（每接收到上位机发送过来数据闪烁一次）。

After receiving the host shutdown command (set frequency $<$ minimum frequency), the compressor stops running and switches to standby. The green light flashes (flashing once every time data is received from the host computer)



5.6 限降频控制 Frequency limit control
5.6.1 压缩机电流限降频控制 (典型值 , 不同压缩机存在差异)

Compressor current limit frequency reduction control (typical value, different compressors are different)

类型 Type	电流有效值 RMS current (Arms)	电流峰值 Peak current (Apeak)
压缩机电流限频值 Compressor current frequency limit	25	/
压缩机电流降频值 Compressor current frequency reduction value	27	/
压缩机电流保护值 Compressor current protection value	29	55

● 注：当母线电压低于 390V 时限制频率升高。

Note: When the bus voltage is lower than 390V, the frequency is limited to increase.

5.6.2 IPM 温度限降频控制 (典型值 , 不同压缩机存在差异)
5.6.2 IPM temperature limit frequency reduction control

(typical value, different compressors are different)

- 当 IPM 温度在 [90, 92) 范围时，限制频率升高；When the IPM temperature is in the range of [90, 92), the limiting frequency will increase;
- 当 IPM 温度在 [92, 95] 范围时，每 20S 降频 1rps (最低降到 30rps)；When the IPM temperature is in the range of [92, 95], the frequency will be reduced by 1rps every 20S (lowest to 30rps);
- 当 IPM 温度高于 95°C 时，则故障停机 (见第 6 章 IPM 模块温度过高保护)。When the IPM temperature is higher than 95°C, the fault will stop (see Chapter 6 IPM Module Over Temperature Protection).



6、故障表 Fault table

6.1 驱动板故障指示灯 Driver board fault indicator

序号 No.	故障类型 Fault type	D1 红 (RED)	D2 绿 (GREEN)	D3 黄 (YELLOW)
1	压缩机电流保护 Compressor current protection	⊙	⊙	⊙
2	IPM 模块保护 IPM module protection	○	⊙	●
3	IPM 模块内部感温电路异常 IPM Internal temperature sensing circuit abnormality	○	●	⊙
4	IPM 模块温度过高保护 IPM module over temperature protection	○	⊙	⊙
5	VDC 电压过高保护 VDC over voltage protection	⊙	○	○
6	VDC 电压过低保护 VDC low voltage protection	●	○	○
7	通讯故障 Communication failure	⊙	⊙	●
8	软件控制异常 Software control error	○	○	○
9	电流检测电路故障 Current detection circuit failure	○	○	●
10	启动失败 Startup failure	○	○	⊙
11	欠相故障 Phase failure	○	⊙	○
12	输入电源异常故障 Abnormal input power failure	⊙	●	○
➤	正常待机 Normal standby	●	⊙	●
➤	正常运行 Normal running	⊙	●	●
➤	在线测试待机 Online test standby	●	●	⊙

● 注：○亮 on ⊙闪 flash ●灭 off



6.2 故障判断条件和停机时长 Fault judgment conditions and downtime

序号 No	故障类型 Fault type	判断条件 Analyzing conditions	停机时长 Off time
1	压缩机电流保护 Compressor current protection	U、V、W 瞬间电流峰值大于 55A (检测时间 400μs) U, V, W instantaneous current peak value is greater than 55A (detection time 400μs)	60 S
2	IPM 模块保护 IPM module protection	IPM 模块检测 FO 引脚输出低电平; The IPM module detects the FO pin outputs low level; MCU 检测到 FO 口有低电平输入; 总线电流大于 DSP 内部比较器设定阈值; MCU detects a low-level input on the FO port; the bus current is greater than the threshold set by the DSP internal comparator;	60 S
3	IPM 模块内部感温电路异常 The temperature sensing circuit inside the IPM module is abnormal	检测到模块内部检测温度的感温包异常 Abnormal temperature sensing bulb inside the module is detected	60 S
4	IPM 模块温度过高保护 IPM module over temperature protection	检测到 IPM 模块温度高于 95℃ The temperature of the IPM module is detected to be higher than 95℃	60 S
5	VDC 电压过高保护 VDC over voltage protection	检测到 VDC 电压高于 700V Detected VDC voltage higher than 700V	60 S
6	VDC 电压过低保护 VDC low voltage protection	检测到 VDC 电压低于 370V Detected VDC voltage lower than 370V	20 S
7	通讯故障 communication fail	连续 15s 内没有收到上位机发过来的数据或收到错误数据 No data sent from the host computer or incorrect data received within 15s	60 S
8	软件控制异常 Software control abnormal	运行转速与设定转速相差 20 rps 以上或失步 The difference between the running speed and the set speed is more than 20 rps or out of step	60 S
9	电流检测电路故障 Current detection circuit failure	检测到电流检测电路发生异常 An abnormality in the current detection circuit is detected	60 S
10	启动失败 Startup failed	启动阶段未能正确的判断到转子位置 The rotor position was not correctly judged during the startup phase	60 S
11	欠相故障 Phase failure	给定输出, 检测不到其中任意一相电流 Given output, no one phase current can be detected	60 S
12	输入电源异常故障 Abnormal input power failure	连续 1s 检测到输入电压高于 520V 或低于 270V Detect input voltage higher than 520V or lower than 270V for 1s period	20 S



6.3 故障排查方法 Troubleshooting method

序号 No.	故障类型 Fault type	排查方法 Method
1	压缩机电流保护 Compressor current protection	1、压缩机相序接错；The phase sequence of the compressor is connected incorrectly; 2、压缩机液积，油积导致电流变大；Compressor fluid accumulation, oil accumulation causes current to increase; 3、压缩机启动压差过大；The compressor start pressure difference is too large; 4、压缩机损坏；The compressor is damaged; 5、驱动板损坏；The drive board is damaged;
2	IPM 模块保护 IPM module protection	1、压缩机相序接错；The phase sequence of the compressor is connected incorrectly; 2、压缩机液积，油积导致电流变大；Compressor fluid accumulation, oil accumulation causes current to increase; 3、压缩机启动压差过大；The compressor start pressure difference is too large; 4、压缩机损坏；The compressor is damaged; 5、驱动板损坏；The drive board is damaged;
3	IPM 模块内部感温电路异常 IPM module inside temperature sensing circuit abnormal	1、驱动板损坏；The drive board is damaged;
4	IPM 模块温度过高保护 IPM module over temperature	1、驱动板模块螺钉没有打紧；The driver board module screws are not tightened; 2、驱动板散热器散热不良；Poor heat dissipation of the drive
5	VDC 电压过高保护 VDC over voltage protection	1、VDC 电压太高，高于 700V；VDC voltage is too high, higher than 700V
6	VDC 电压过低保护 VDC low voltage protection	1、VDC 电压太低，低于 370V；VDC voltage is too low, lower than 370V
7	通讯故障 communication failure	1、与主控板通讯线松脱；The communication cable with the main control board is loose; 2、驱动板损坏；The drive board is damaged;



8	软件控制异常 Software control error	1、压缩机内部有杂质，导致频率无法稳定；There are impurities inside the compressor, causing the frequency to be unstable;
9	电流检测电路故障 Current detection circuit	1、驱动板损坏；The drive board is damaged
10	启动失败 Startup failure	1、启动前压缩机有液积；The compressor has liquid accumulation before starting; 2、压缩机启动压差过大；The compressor start pressure difference is too large; 3、压缩机相序接错；The phase sequence of the compressor is connected incorrectly;
11	欠相故障 Phase fault	1、压缩机相线少接了 1 相或 2 相；Compressor phase wire is less connected to 1 or 2 phases
12	输入电源异常故障 Abnormal input power failure	1、机组断电后 40s 内再上电，驱动板电容没有放完电；The unit is powered on again within 40s after the power is cut off, and the drive board capacitor is not completely discharged; 2、电源线接线不良；Poor wiring of the power cord; 3、驱动板输入电源采样电路故障；The input power sampling circuit of the drive board is faulty;



7、驱动板接口定义 Driver board interface definition

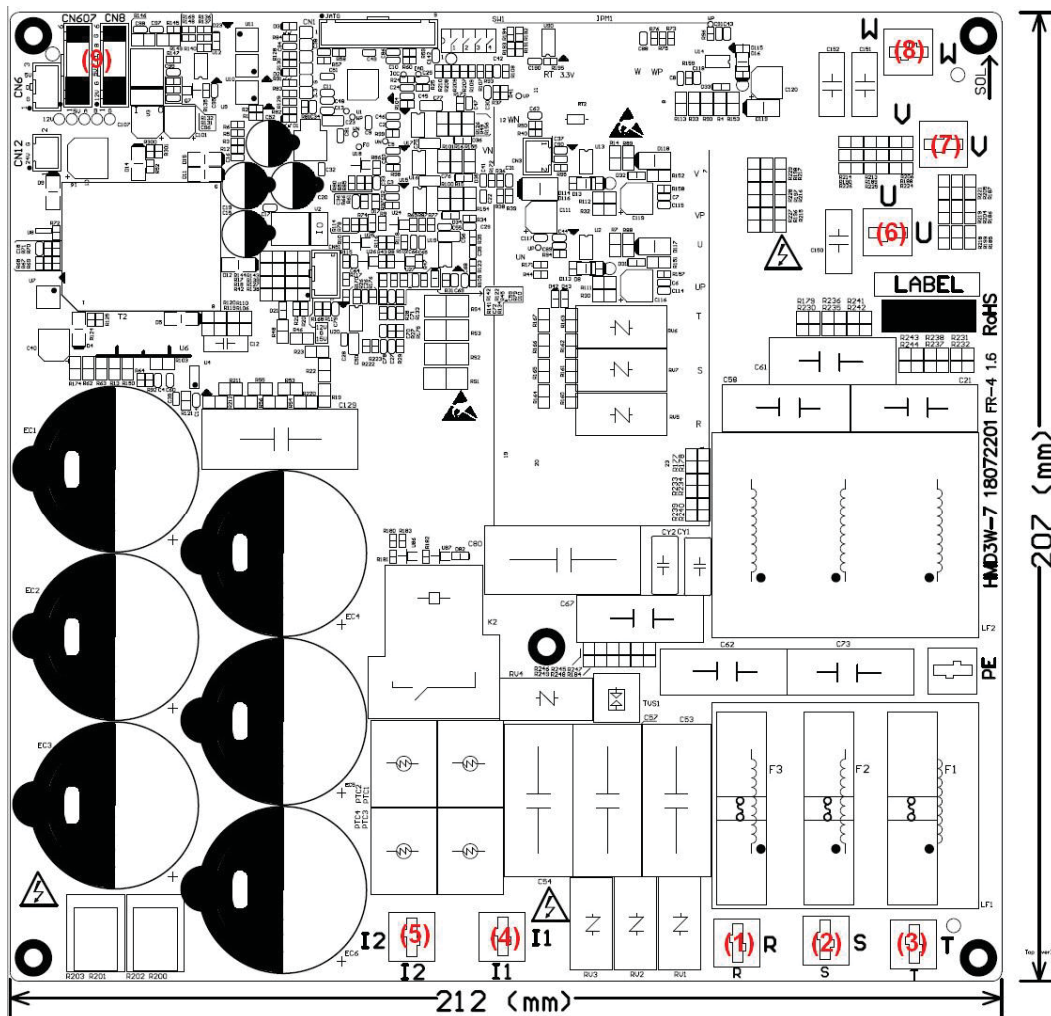

7.1 接线位置说明 Wiring position description

1	R	三相火线 R 输入 Three-phase live wire R input	2	S	三相火线 S 输入 Three-phase live wire S input
3	T	三相火线 T 输入 Three-phase live wire T input	4	I1	接电抗器 Reactor
5	I2	接电抗器 Reactor	6	U	接压缩机 U 相 Compressor U phase
7	V	接压缩机 V 相 Compressor V phase	8	W	接压缩机 W 相 Compressor W phase
9	CN607	与主控板通讯接口 Connect with the main control board			

7.2 拨码说明 Code description

● 注：具体联系客服人员。Please contact with our customer service for more details.



8、安装尺寸 Mounting dimensions

243 (长 L) * **238** (宽 W) * **81** (顶高 H) 单位 mm

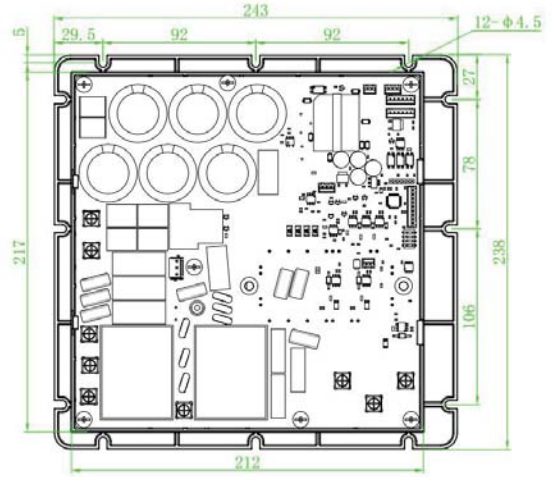
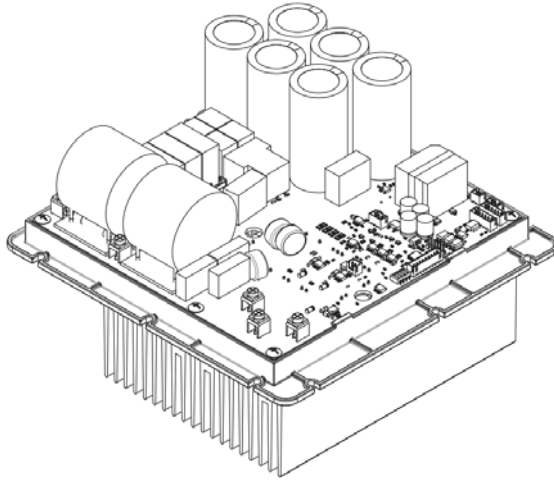

建议钣金开口尺寸: 202X162mm

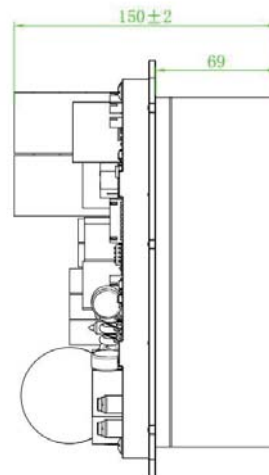
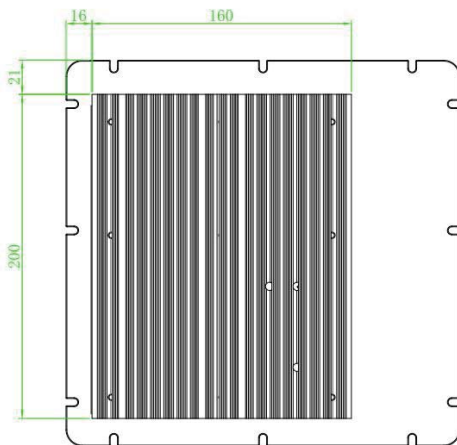

- 注：驱动板散热器有多款尺寸，此处略。具体请联系客服。

Note: There are many sizes of drive board radiators. Please contact customer service for details.



9、通讯接口 Communication Interface

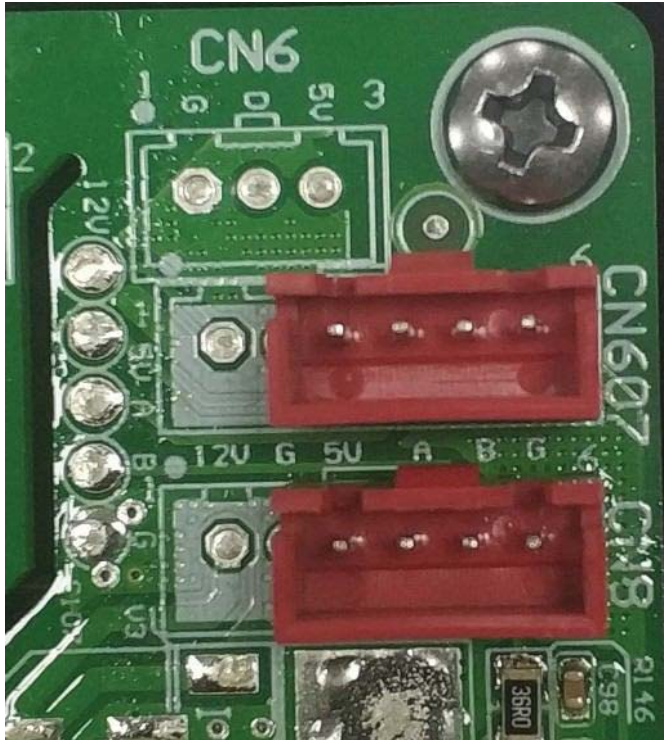

9.1RS485 通讯接口 RS485Communication Interface

通讯端口	CN607、CN8					
+5V 通讯	/	/	+5V	A	B	GND

- 注：通讯波特率 2400bps，具体通讯协议请联系客服。

The communication baud rate is 2400bps, please contact customer service for specific communication protocol.



10、 可选择配件 Optional accessories

10.1 电抗器 Reactor

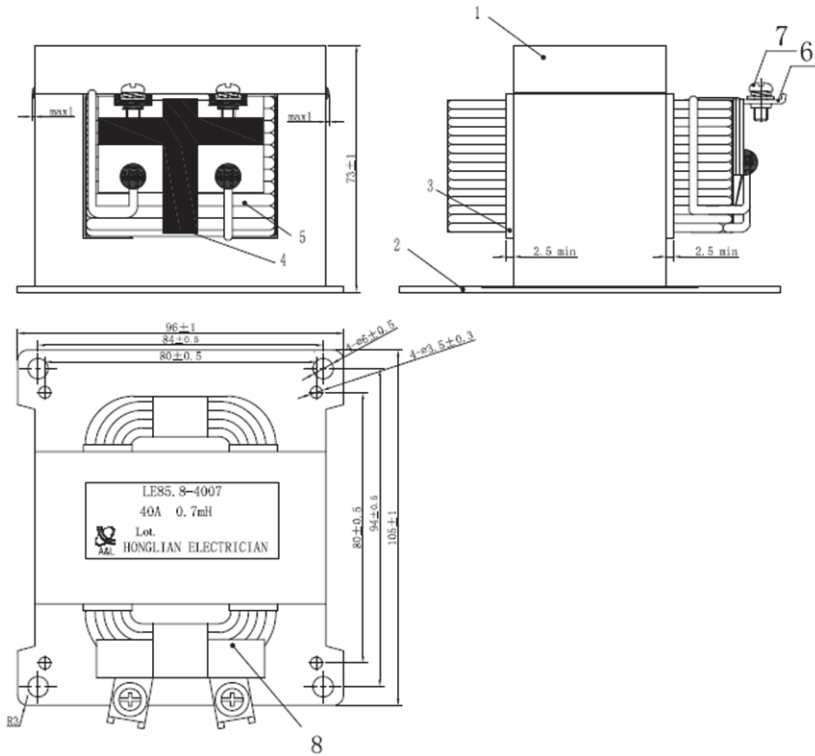

10.2 配件列表 Accessories list

序号 No.	类型 Item	型号 Type	图片 Phot	作用 Function
1	电抗器 Reactor	电抗器 Reactor 0.7mH/40A		减少对电源的谐波影响 Reduce the harmonic effects on the power supply



11、 接线图Wiring diagram

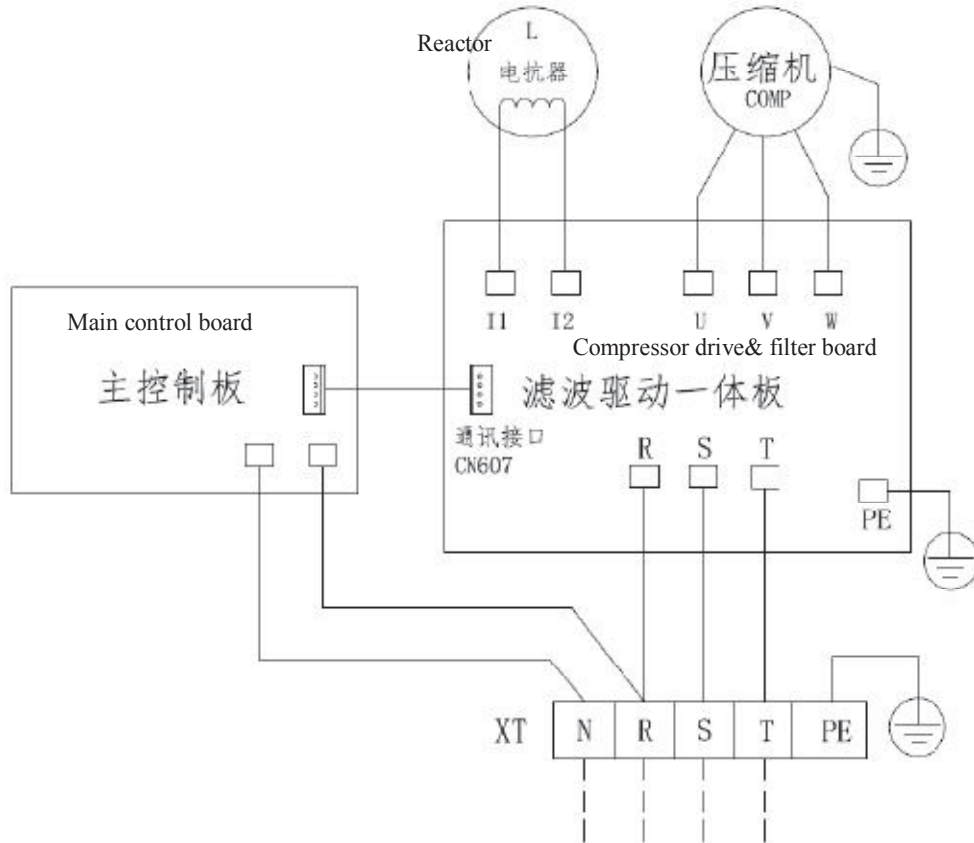

12、 运行电流波形Running current waveform

